

ABSOLUTE Solar Digimatic Indicator ID-S

543 Series – With Simple Design

FEATURES

- Mitutoyo's unique ABSOLUTE sensor automatically restores the last origin position when the indicator is turned on. This allows quick-start operation, which is particularly useful in multipoint measurement.
- Measurement tool with a solar power source. Ready for use from 40 lux illumination.
- Similar in size to Series 2 dial indicators.
- SPC output provided.
- Two large buttons (three on inch/mm models) improve functionality.



SPECIFICATIONS

Inch/Metric with 3/8" dia. Stem, #4-48UNF Thread

Order	Model	Range	Resolution	Accuracy	Stem Diameter	Measuring Force	Back Type
543-502	ID-S112ES	.5"/12.7mm	.00005"/0.001mm	.0001"/0.003mm	3/8" (ANSI/AGD)	1.5N or less	Lug Back
543-502B	ID-S112ESB	.5"/12.7mm	.00005"/0.001mm	.0001"/0.003mm	3/8" (ANSI/AGD)	1.5N or less	Flat Back
543-507	ID-S1012ES	.5"/12.7mm	.0005"/0.01mm	.001"/0.02mm	3/8" (ANSI/AGD)	1.5N or less	Lug Back
543-507B	ID-S1012ESB	.5"/12.7mm	.0005"/0.01mm	.001"/0.02mm	3/8" (ANSI/AGD)	1.5N or less	Flat Back

Metric with 8mm dia. Stem, M2.5x.45 Thread

Order	Model	Range	Resolution	Accuracy	Stem Diameter	Measuring Force	Back Type
543-500	ID-S112S	12.7mm	0.001mm	0.003mm	8mm (ISO)	1.5N or less	Lug Back
543-500B	ID-S112SB	12.7mm	0.001mm	0.003mm	8mm (ISO)	1.5N or less	Flat Back
543-505	ID-S1012S	12.7mm	0.01mm	0.02mm	8mm (ISO)	1.5N or less	Lug Back
543-505B	ID-S1012SB	12.7mm	0.01mm	0.02mm	8mm (ISO)	1.5N or less	Flat Back

Inch/Metric with 8mm dia. Stem, M2.5x.45 Thread

Order	Model	Range	Resolution	Accuracy	Stem Diameter	Measuring Force	Back Type
543-501	ID-S112MS	.5"/12.7mm	.00005"/0.001mm	.0001"/0.003mm	8mm (ISO)	1.5N or less	Lug Back
543-501B	ID-S112MSB	.5"/12.7mm	.00005"/0.001mm	.0001"/0.003mm	8mm (ISO)	1.5N or less	Flat Back
543-506	ID-S1012MS	.5"/12.7mm	.0005"/0.01mm	.001"/0.02mm	8mm (ISO)	1.5N or less	Lug Back
543-506B	ID-S1012MSB	.5"/12.7mm	.0005"/0.01mm	.001"/0.02mm	8mm (ISO)	1.5N or less	Flat Back

Technical Data

Accuracy: Refer to the list of specifications
 Resolution: 0.01mm, 0.001mm, .00005"/0.001mm, or .0005"/0.01mm
 Display: LCD
 Length Standard: ABSOLUTE electrostatic capacitance-type linear encoder
 Max. Response Speed: Unlimited
 Measuring Force: Refer to the list of specifications
 Battery: Solar Battery*
 Dust/Water Protection Level: IP42
 *Can be used continuously above 40 lux

Function

Origin Set, Counting Direction Switching, in/mm conversion

Optional Accessories

- 21EZA198 Lifting lever (mm)
- 21EZA199 Lifting lever (inch)
- 540774 Lifting cable
- 21EZA105 Lifting knob (mm)
- 21EZA150 Lifting knob (inch)
- 905338 SPC cable (1m)
- 905409 SPC cable (2m)
- : Backs (See page F-33.)
- : Contact points (See page F-34.)

About the charge function:

Reserve capacity allows a fully charged ID-S Solar to be used for about 3.5 hours under light conditions below the minimum level. The charging time differs depending on the environment, but it usually takes about 1.5 hours for a fully discharged ID-S Solar to fully recharge under light conditions of 500 lux.

DIMENSIONS

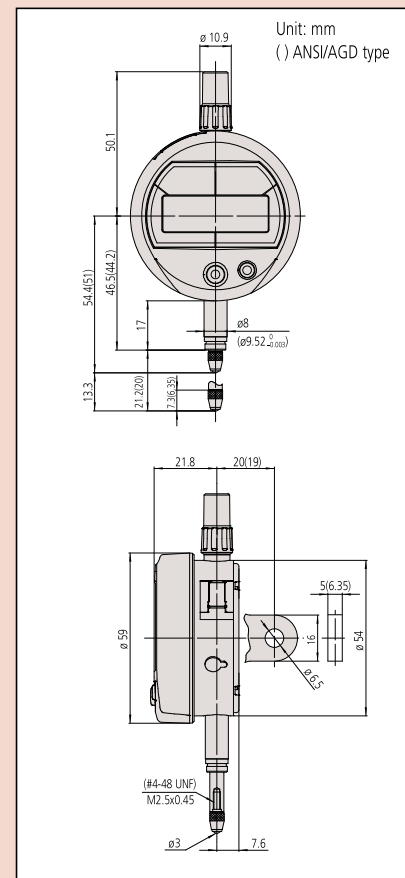



ABSOLUTE Digimatic Indicator ID-S

SERIES 543 — with Simple Design

FEATURES

- After the initial zero-setting with the Origin button, the repeated absolute positioning is no longer necessary over entire battery life.
- Unlimited response speed eliminates over-speed errors
- Similar in size to standard Series 2 dial indicators.
- SPC data output.

Technical Data

Accuracy: Refer to the list of specifications
 Resolution: 0.01mm, 0.001mm, .0005"/0.01mm, .0001"/0.001mm or .00005"/0.001mm
 Display: LCD
 Length standard: ABSOLUTE electrostatic capacitance-type linear encoder
 Max. response speed: Unlimited
 Measuring force: Refer to the list of specifications
 Battery: SR44 (1 pc.), **938882**
 Battery life: Approx. 20,000 hours under normal use
 Dust/Water protection level: IP42 (IP53: **543-794B**, **543-795B**, **543-796B**)
 Inspection certificate is included.

Function

Origin-set, Zerose, Counting direction switching, Power ON/OFF, Data output, inch/mm conversion (on inch/metric models only)
 Alarm: Low voltage, Counting value composition error, Over-flow error

Optional Accessories

- 905338:** SPC cable (40" / 1m)
- 905409:** SPC cable (80" / 2m)
- 21EZA198:** Spindle lifting lever (ISO/JIS type)
- 21EZA199:** Spindle lifting lever (ANSI/AGD type)
- 540774:** Spindle lifting cable (stroke: .4" / 10mm)
- 21EZA105:** Lifting knob (mm)
- 21EZA150:** Lifting knob (inch)
- 125317:** Spare rubber boot (for dust-proof type)
- : Backs (See page F-33.)
- : Contact points (See page F-34.)



SPECIFICATIONS

Inch/Metric Stem dia. 3/8", #4-48 UNF Thread ISO/JIS type ANSI/AGD type

Resolution	Range	Order No.		Model	Accuracy	Measuring force	Remarks
		w/ lug back	w/ flat-back				
.00005"/0.001mm	.5" / 12.7mm	543-792	543-792B	ID-S112EX	±.0001"	1.5N or less	—
.00005"/0.001mm	.5" / 12.7mm	543-796	543-796B	ID-S112PEX	±.0001"	2.5N	Dust-proof
.0001"/0.001mm	.5" / 12.7mm	543-793	543-793B	ID-S112TX	±.0001"	1.5N or less	—
.0005"/0.01mm	.5" / 12.7mm	543-783	543-783B	ID-S1012EX	±.0010"	1.5N or less	—

Inch/Metric Stem ø 8mm, M2.5 x 0.45 Thread

Resolution	Range	Order No.		Model	Accuracy	Measuring force	Remarks
		w/ lug back	w/ flat-back				
.00005"/0.001mm	.5" / 12.7mm	543-791	543-791B	ID-S112MX	±.0001"	1.5N or less	—
.00005"/0.001mm	.5" / 12.7mm	543-795	543-795B	ID-S112PMX	±.0001"	2.5N or less	Dust-proof
.0005"/0.01mm	.5" / 12.7mm	543-782	543-782B	ID-S1012MX	±.0008"	1.5N or less	—

Metric Stem ø 8mm, M2.5 x 0.45 Thread

Resolution	Range	Order No.		Model	Accuracy	Measuring force	Remarks
		w/ lug back	w/ flat-back				
0.001mm	12.7mm	543-790	543-790B	ID-S112X	0.003mm	1.5N or less	—
0.001mm	12.7mm	543-794	543-794B	ID-S112PX	0.003mm	2.5N or less	Dust-proof
0.01mm	12.7mm	543-781	543-781B	ID-S1012X	0.02mm	1.5N or less	—

DIMENSIONS

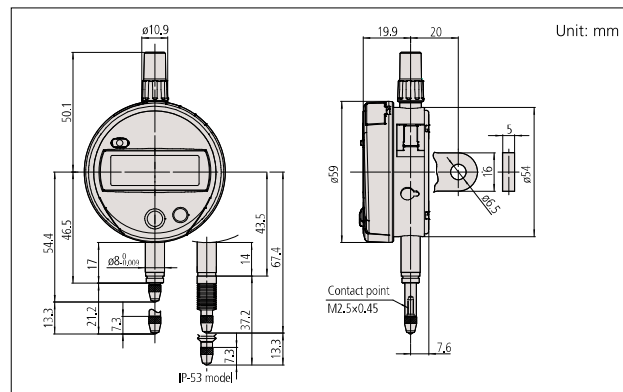

Note 1: Dimensions of the inch (ANSI/AGD Type) dial indicator partly differ from those of the metric (ISO/JIS Type) indicator.

Note 2: Inch (ANSI/AGD Type) dial indicators are provided with a stem of 3/8" dia. and #4-48UNF thread mount for the contact point.

ABSOLUTE Digimatic Indicator ID-U

SERIES 575 — With Slim and Simple Design

FEATURES

- Slim digital indicator with low price.
- Large LCD and simple key operation.
- After the initial origin setting, the ID-U no longer needs absolute positioning over entire battery life; the origin is remembered even after power-off.
- Ideal for installation into measuring devices because of compact design and long battery life.
- Employing the ABSOLUTE linear encoder, the ID-U always displays the spindle "Absolute Position" from the origin at power-on. Also unlimited response speed eliminates over-speed errors.
- Flat back type only has no option for backs.
- SPC data output.



SPECIFICATIONS

Inch/Metric Stem dia. 3/8", #4-48 UNF Thread ISO/JIS type ANSI/AGD type

Resolution	Range	Order No.	Model	Accuracy	Measuring force
.0005"/0.01mm	1" / 25.4mm	575-123	ID-U1025E	.0008"	1.8N or less

Inch/Metric Stem \varnothing 8mm, M2.5 x 0.45 Thread

Resolution	Range	Order No.	Model	Accuracy	Measuring force
.0005"/0.01mm	1" / 25.4mm	575-122	ID-U1025M	.0008"	1.8N or less

Metric Stem \varnothing 8mm, M2.5 x 0.45 Thread

Resolution	Range	Order No.	Model	Accuracy	Measuring force
0.01mm	25.4mm	575-121	ID-U1025	0.02mm	1.8N or less

DIMENSIONS

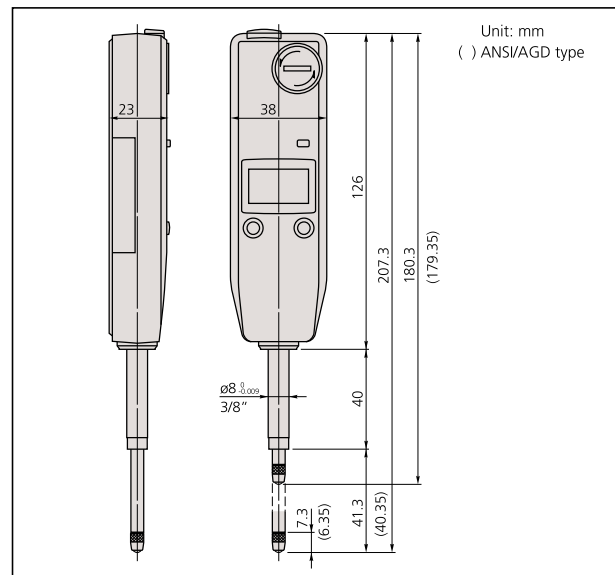

Technical Data

Accuracy: Refer to the list of specifications
 Resolution: 0.01mm or .0005"/0.01mm,
 Display: LCD
 Length standard: ABSOLUTE electrostatic capacitance type linear encoder
 Max. response speed: Unlimited
 Measuring force: Refer to the list of specifications
 Battery: SR44 (1 pc.), **938882**
 Battery life: Approx. 20,000 hours under normal use
 Dust/Water protection level: IP42

Function

Origin-set, Zeroset, Counting direction switching, Power ON/OFF, Data output, inch/mm conversion (on inch/metric models only)
 Alarm: Low voltage, Counting value composition error, Over-flow error

Optional Accessories

- 905338:** SPC cable (40" / 1m)
- 905409:** SPC cable (80" / 2m)
- 540774:** Spindle lifting cable (stroke: .4" / 10mm)
- : Contact points (See page F-34.)

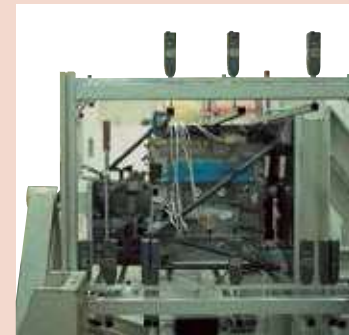

Application example

ABSOLUTE Digimatic Indicator ID-C

SERIES 543 — Standard Type



ABSOLUTE
Absolute System Patented by MITUTOYO



Technical Data

Accuracy: Refer to the list of specifications

Resolution:	0.01mm type	0.01mm
	0.001mm type*	0.001mm/0.01mm
	.0005"/0.01mm type	.0005"/0.01mm
	.00005"/0.001mm type*	.0005"/.0001"/.00005"/.01mm/0.001mm

* Switchable resolution

Display: LCD

Length standard: ABSOLUTE electrostatic capacitance type linear encoder

Max. response speed: Unlimited

Measuring force: Refer to the list of specifications

Battery: SR44 (1 pc.), **938882**

Battery life: Approx. 7,000 hours under normal use

Dust/Water protection level: IP42

Inspection certificate is included

Function

Origin-set/Preset, Zeroset, go/no-go judgment, Counting direction switching, Power ON/OFF, Data output, inch/mm conversion (on inch/metric models only)

Alarm: Low voltage, Counting value composition error, Over-flow error, Tolerance limit setting error

Internal calculations using the simple formula of $[F(x) = Ax]$ are available.

Optional Accessories

905338: SPC cable (40" / 1m)

905409: SPC cable (80" / 2m)

21EZA198: Spindle lifting lever (ISO/JIS type)*

21EZA199: Spindle lifting lever (ANSI/AGD type)*

21EZA105: Spindle lifting knob (12.7mm/.5" ISO/JIS type)**

21EZA150: Spindle lifting knob (12.7mm/.5" ANSI/AGD type)**

21EZA197: Spindle lifting knob (25.4mm/1", 50.8mm/2" models)

21EZA200: Spindle lifting knob (50.8mm/2")

540774: Spindle lifting cable (stroke: (1"/ 25.4mm)

02ACA571: Auxiliary spindle spring for 25mm/1" models***

02ACA773: Auxiliary spindle spring for 50mm/2" models***

—: Backs (See page F-33.)

—: Contact points (See page F-34.)

* Can be used on 12mm/.5" models only.

** Not available for low measuring force models.

*** Required when orienting gage upside down.

FEATURES

- Similar in size to Series 2 dial indicators.
- Large, easy-to-read LCD.
- Go/no-go judgment can be performed by setting upper and lower tolerance limits. The judgment result (go/no-go) can be displayed in full-size characters.
- The positive/negative count resulting from the spindle's up/down movement can be toggled.
- Internal calculations using the simple formula of $[F(x) = Ax]$ are available.
- Employing the ABSOLUTE linear encoder, the ID-C always displays the spindle "Absolute Position" from the origin at power-on. Also unlimited response speed eliminates over-speed errors.
- The ID-C indicator face can be rotated 330° to an appropriate angle for easy reading.
- With SPC data output.



Mitutoyo

SPECIFICATIONS

Inch/Metric Stem dia. 3/8", #4-48 UNF Thread ISO/JIS type ANSI/AGD type

Resolution	Range	Order No. (w/lug, flat-back)		Model	Accuracy	Measuring force	Remarks
.0005"/0.001mm*	.5" / 12.7mm	543-392	543-392B	ID-C112EXB	.0001"	1.5N or less	—
.0005"/0.001mm*	.5" / 12.7mm	543-396	543-396B	ID-C112CEX	.0001"	0.4N - 0.7N	Low measuring force
.0005"/0.001mm*	1" / 25.4mm	—	543-472B	ID-C125EXB	.0001"	1.8N or less	—
.0005"/0.001mm*	2" / 50.8mm	—	543-492B	ID-C150EXB	.0002"	2.3N or less	—
.0005"/0.01mm	.5" / 12.7mm	543-402	543-402B	ID-C1012EX	.001"	0.9N or less	—
.0005"/0.01mm	.5" / 12.7mm	543-406	543-406B	ID-C1012CEX	.001"	0.2N - 0.5N	Low measuring force
.0005"/0.01mm	1" / 25.4mm	—	543-476B	ID-C1025EXB	.001"	1.8N or less	—
.0005"/0.01mm	2" / 50.8mm	—	543-496B	ID-C112CEXB	.0016"	2.3N or less	—

* Switchable Resolution Type

Inch/Metric Stem ø 8mm, M2.5 x 0.45 Thread

Resolution	Range	Order No. (w/lug, flat-back)		Model	Accuracy	Measuring force	Remarks
.0005"/0.001mm*	.5" / 12.7mm	543-391	543-391B	ID-C112MX	.0001"	1.5N or less	—
.0005"/0.001mm*	.5" / 12.7mm	543-395	543-395B	ID-C112CMX	.0001"	0.4N - 0.7N	Low measuring force
.0005"/0.001mm*	1" / 25.4mm	—	543-471B	ID-C125MXB	.0001"	1.8N or less	—
.0005"/0.001mm*	2" / 50.8mm	—	543-491B	ID-C150MXB	.0002"	2.3N or less	—
.0005"/0.01mm	.5" / 12.7mm	543-401	543-401B	ID-C1012MX	.001"	0.9N or less	—
.0005"/0.01mm	.5" / 12.7mm	543-405	543-405B	ID-C1012CMX	.001"	0.2N - 0.5N	Low measuring force
.0005"/0.01mm	1" / 25.4mm	—	543-475B	ID-C1025MXB	.001"	1.8N or less	—
.0005"/0.01mm	2" / 50.8mm	—	543-495B	ID-C1050MXB	.0016"	2.3N or less	—

* Switchable Resolution Type

Metric Stem ø 8mm, M2.5 x 0.45 Thread

Resolution	Range	Order No. (w/lug, flat-back)		Model	Accuracy	Measuring force	Remarks
0.001mm*	12.7mm	543-390	543-390B	ID-C112X	0.003mm	1.5N or less	—
0.001mm*	12.7mm	543-394	543-394B	ID-C112CX	0.003mm	0.4N - 0.7N	Low measuring force
0.001mm*	25.4mm	—	543-470B	ID-C125XB	0.003mm	1.8N or less	—
0.001mm*	50.8mm	—	543-490B	ID-C150XB	0.006mm	2.3N or less	—
0.01mm	12.7mm	543-400	543-400B	ID-C1012X	0.02mm	0.9N or less	—
0.01mm	12.7mm	543-404	543-404B	ID-C1012CX	0.02mm	0.2N - 0.5N	Low measuring force
0.01mm	25.4mm	—	543-474B	ID-C1025XB	0.03mm	1.8N or less	—
0.01mm	50.8mm	—	543-494B	ID-C1050XB	0.04mm	2.3N or less	—

* Switchable Resolution Type

DIMENSIONS

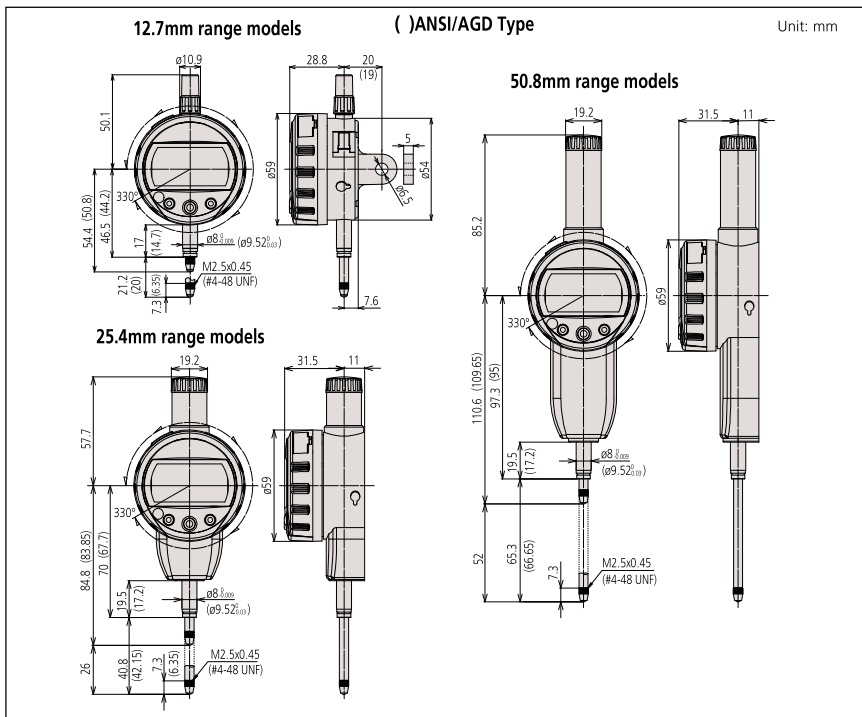

330° Rotary display

The display can be rotated 330°, allowing use at a position where you can easily read the measurement value.

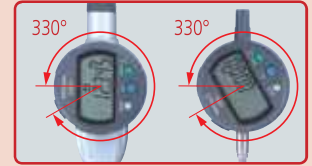

Calculation: f(x) = Ax

Mounting the ID-C on a measuring jig and setting the multiplying factor A (to any value) allows direct measurement without using a conversion table and improves measurement efficiency.



Application example

Function locking

Ensures reliability of measurement by locking the settings to prevent preset function settings from being changed by mistake.



Setting measuring force on low measuring force models.

•543-404/404B/405/405B/406/406B

Spindle orientation	Spring	Weight (approximately 0.1N)	Maximum measuring force
Pointing vertically downward	Yes	Yes	0.5N
	Yes	No	0.4N
	No	Yes	0.3N
Horizontal	No	No	0.2N
	Yes	No	0.2N

Note: Operation using configurations other than shown above is not guaranteed.

•543-394/394B/395/395B/396/396B

Spindle orientation	Spring	Weight (approximately 0.1N)	Maximum measuring force
Pointing vertically downward	Yes	Yes	0.7N
	Yes	No	0.6N
	No	Yes	0.4N
	No	No	Not guaranteed
Horizontal	Not guaranteed		

Note: Operation using configurations other than shown above is not guaranteed.



Technical Data

Accuracy: Refer to the list of specifications
 Resolution: 12 Steps
 .00005/.0001/.0005"
 0.001/0.01mm
 Display: LCD
 Length standard: ABSOLUTE electrostatic capacitance-type linear encoder
 Max. response speed: Unlimited
 Measuring force: Refer to the list of specifications
 Battery: CR2032 (1 pc.), **05SAA217**
 Battery life: Approx. 12 months under normal use
 IP Rating: Equivalent to IP-42¹

¹ A protection class indication (IP=International Protection) is based on the IEC 60529 /DIN40050 part 1/JIS D0207, C0920. The level indicated is valid only if the output connector cap is installed.

Function

Key Lock, Parameter Lock, PC-USB Input, Analog Bar, FAST measurement frequency, Preset (up to 3 values), Tolerance Judgment, Peak Detection, Calculation, inch/mm conversion (on inch/metric models only), Counting direction switching, Data Output
 Alarm: Low voltage, Counting value composition error, Over-flow error, Tolerance limit setting error

Optional Accessories

- 905338:** Connecting Cable (1m)
- 905409:** Connecting Cable (2m)
- 21EZA313:** Parameter Setting USB Cable
- 21EZA198:** Spindle lifting lever (12.7mm ISO/JIS type)
- 21EZA199:** Spindle lifting lever (12.7mm ASME/AGD type)
- 21EZA105:** Lifting Knob (12.7mm/.5" ISO/JIS Models)
- 21EZA150:** Lifting Knob (12.7mm/.5" ASME/AGD Models)
- 21EZA197:** Lifting Knob (for 25.4/1" mm models)
- 21EZA200:** Lifting Knob (for 50.8/2" mm models)
- 540774:** Spindle lifting cable
- : Backs (See page F-33.)
- : Contact points (See page F-34.)

APPLICATIONS



- Various fixtures suited for individual workpieces can be prepared.
- Measuring accuracy is subject to fixture accuracy

ABSOLUTE Digimatic Indicator ID-C

SERIES 543 — Calculation Type

FEATURES

- The new Calculation-Type Digimatic Indicator features both a Key-Lock and Parameter-Lock to prevent accidental changing of settings during operation.
- Improved parameter setting software makes easy to set all available parameters, and determine and upload the proper coefficients for calculation. (optional)
- Fast measurement frequency allows the user to increase the number of readings per second from 10 to 50, allowing higher accuracy measurements of TIR and MAX/MIN.
- An analog bar provides easy-to-read values when scanning for Max, Min, and TIR Values.
- The Absolute Digimatic indicator performs internal calculations using the formula $Ax+B+Cx-1$ (assuming spindle displacement as x) while the specified coefficients A , B and C can be set with respect to the purpose of measurement or dimensions of the fixtures. This unique features allows you to read your measurements directly, without the need for conversions.



543-342B

SPECIFICATIONS

ISO/JIS type ANSI/AGD type

Inch/Metric Stem dia. 3/8" #4-48 UNF Thread

Resolution	Range	Order No.*	Model	Accuracy	Measuring Force
.00005/.0001/.0005"	.5"/12.7mm	543-342B	ID-C112REXB	±.00010"/0.003mm	1.5N or less
0.001/0.01mm	1"/25.4mm	543-592B	ID-C125REXB	±.00010"/0.003mm	1.8N or less
Selectable	2"/50.8mm	543-597B	ID-C150REXB	±.00025"/0.006mm	2.3N or less

Inch/Metric Stem ø 8mm, M2.5 x 0.45 Thread

Resolution	Range	Order No.*	Model	Accuracy	Measuring Force
.00005/.0001/.0005"	.5"/12.7mm	543-341B	ID-C112RMXB	±.00010"/0.003mm	1.5N or less
0.001/0.01mm	1"/25.4mm	543-591B	ID-C125RMXB	±.00010"/0.003mm	1.8N or less
Selectable	2"/50.8mm	543-596B	ID-C150RMXB	±.00025"/0.006mm	2.3N or less

Metric Stem ø 8mm, M2.5 x 0.45 Thread

Resolution	Range	Order No.*	Model	Accuracy	Measuring Force
0.001/0.01mm	.5"/12.7mm	543-340B	ID-C112RXB	0.003mm	1.5N or less
Selectable	1"/25.4mm	543-590B	ID-C125RXB	0.003mm	1.8N or less
	2"/50.8mm	543-595B	ID-C150RXB	0.006mm	2.3N or less

*Flat back

DIMENSIONS

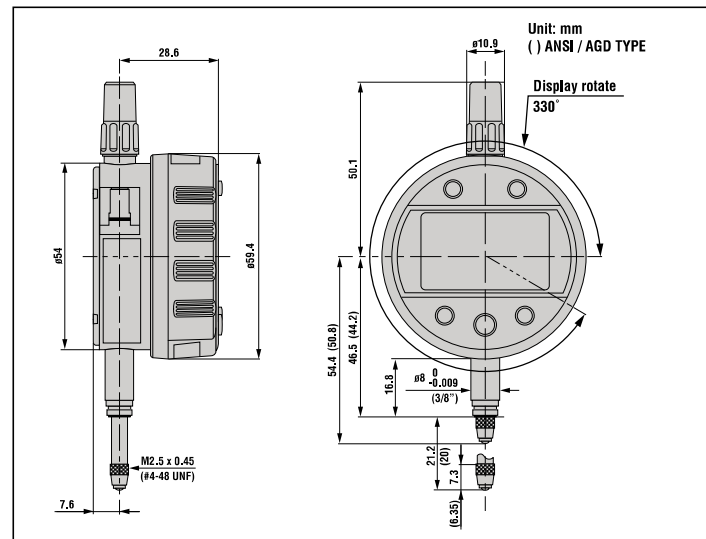

ABSOLUTE Digimatic Indicator ID-C

SERIES 543 — With Max./Min. Value Holding Function

FEATURES

- The new Peak Hold-Type Digimatic Indicator features both a Key-Lock and Parameter-Lock to prevent accidental changing of settings during operation.
- Parameter setting software makes it even easy to set all available parameters.
- An analog bar provides easy-to-read values when scanning for Max, Min and TIR Values.
- The maximum, minimum or runout value can be displayed during measurement.
- Go/no-go judgment is performed by setting the upper and lower tolerances for max., min. and runout values.
- High speed sampling ratio of 50 times/s.
- Employing the ABSOLUTE linear encoder, the Signal ID-C always displays the spindle Absolute Position from the origin when turned on.



543-302B

SPECIFICATIONS

ISO/JIS type ANSI/AGD type

Inch/Metric		Stem dia. 3/8" #4-48 UNF Thread		Model	Accuracy
Resolution	Range	Order No.	Order No.		
		w/lug	Flat-back		
.00005/.0001/.0005" 0.001/0.01mm Selectable	.5"/12.7mm	543-302	543-302B	ID-C112AEX(B)	±.00010"/0.003mm

Inch/Metric		Stem ø 8mm, M2.5 x 0.45 Thread		Model	Accuracy
Resolution	Range	Order No.	Order No.		
		w/lug	Flat-back		
.00005/.0001/.0005" 0.001/0.01mm Selectable	.5"/12.7mm	543-301	543-301B	ID-C112AMX(B)	±.00010"/0.003mm

Metric		Stem ø 8mm, M2.5 x 0.45 Thread		Model	Accuracy
Resolution	Range	Order No.	Order No.		
		w/lug	Flat-back		
0.001-0.01mm Selectable	12.7mm	543-300	543-300B	ID-C112AX(B)	0.003mm

DIMENSIONS

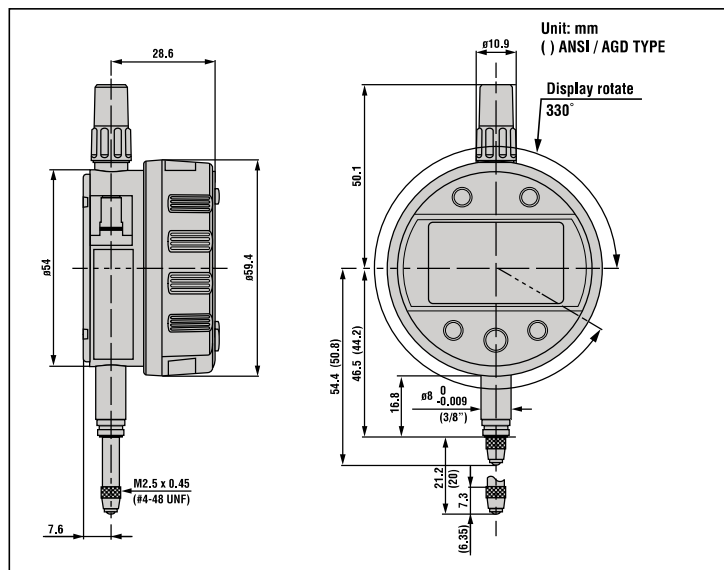

Technical Data

Accuracy: Refer to the list of specifications
 Resolution: 0.001-0.01mm or .00005-.0005"/0.001-0.01mm
 Display: LCD
 Length standard: ABSOLUTE electrostatic capacitance-type linear encoder
 Max. response speed: Unlimited
 Measuring force: 1.5N or less
 Battery: CR2032 (1 pc.), **055AA217**
 Battery life: Approx. 12 months under normal use
 IP Rating: Equivalent to IP-42¹

¹A protection class indication (IP=International Protection) is based on the IEC 60529 /DIN40050 part 1/JIS D0207, C0920. The level indicated is valid only if the output connector cap is installed.

Function

Key Lock, Parameter Lock, PC-USB Input, Analog Bar, Fast measurement frequency, Preset (up to 3 values), Tolerance Judgment, Peak Detection, Calculation (Ax), inch/mm conversion (on inch/metric models only) Counting direction switching, Data Output
 Alarm: Low voltage, Counting value composition error, Overflow error, Tolerance limit setting error

Optional Accessories

- 905338:** Connecting Cable (1m)
- 905409:** Connecting Cable (2m)
- 21EZA313:** Parameter Setting USB Cable
- 21EZA198:** Spindle lifting lever (12.7mm ISO/JIS type)
- 21EZA199:** Spindle lifting lever (12.7mm ASME/AGD type)
- 21EZA105:** Lifting Knob (12.7mm/.5" ISO/JIS models)
- 21EZA150:** Lifting Knob (12.7mm/.5" ASME/AGD models)
- 21EZA197:** Lifting Knob (for 25.4/1" mm models)
- 21EZA200:** Lifting Knob (for 50.8/2" mm models)
- 540774:** Spindle lifting cable
- : Backs (See page F-33.)
- : Contact points (See page F-34.)



Technical Data

Accuracy: Refer to the list of specifications
 Resolution: 0.001-0.01mm or
 .00005-.0005"/0.001-0.01mm
 Display: LCD
 Length standard: ABSOLUTE electrostatic capacitance type
 linear encoder
 Max. response speed: Unlimited
 Measuring force: 1.5N or less
 Battery: CR2032 (1 pc.), **055AA217**
 Battery life: Approx. 12 months under normal use
 IP Rating: Equivalent to IP-42¹⁾

¹⁾ A protection class indication (IP=International Protection) is based on the IEC 60529 /DIN40050 part 1/JIS D0207, C0920. The level indicated is valid only if the output connector cap is installed.

Function

Key Lock, Parameter Lock, PC-USB Input, Analog Bar, Fast measurement frequency, Preset (up to 3 values), Tolerance Judgment, Peak Detection (Min Only), inch/mm conversion (on inch/metric models only), Data Output
 Alarm: Low voltage, Counting value composition error, Overflow error, Tolerance limit setting error

Optional Accessories

905338: Connecting Cable (1m)
905409: Connecting Cable (2m)
21EZA313: Parameter Setting USB Cable
 Applicable Gages Series 511 and 526



Installed on optional bore gage probe (511-703)

ABSOLUTE Digimatic Indicator ID-C

SERIES 543 — Specially Designed for Bore Gage Application

FEATURES

- The new Bore Gage-Type Digimatic Indicator features both a Key-Lock and Parameter-Lock to prevent accidental changing of settings during operation.
- Parameter setting software makes it easy to set all available parameters. (optional)
- Fast measurement frequency allows the user to increase the number of readings per second from 10 to 50.
- The minimum value holding function provides the easy detection of hole diameter.
- An analog bar indicator is integrated to enhance the intuition in reading.
- Go/no-go judgment is performed by setting the upper and lower tolerances.
- Up to three sets of master values and upper/lower tolerance values can be memorized.
- Employing the ABSOLUTE linear encoder, the ID-C always displays the spindle Absolute Position from the origin when turned on.



543-310B

SPECIFICATIONS

ISO/JIS type ANSI/AGD type

Inch/Metric	Stem dia. 3/8" #4-48 UNF Thread	Resolution	Range	Order No.	Model	Accuracy	Measuring Force
		.00005/.0001/.0005"	.5"/12.7mm	543-312B	ID-C112GEXB	±.00010"/0.003mm	1.5N or less
		0.001/0.01mm Selectable					

Inch/Metric	Stem ø 8mm, M2.5 x 0.45 Thread	Resolution	Range	Order No.	Model	Accuracy	Measuring Force
		.00005/.0001/.0005"	.5"/12.7mm	543-311B	ID-C112GMXB	±.00010"/0.003mm	1.5N or less
		0.001/0.01mm Selectable					

Metric	Stem ø 8mm, M2.5 x 0.45 Thread	Resolution	Range	Order No.	Model	Accuracy	Measuring Force
		0.001/0.01mm Selectable	12.7mm	543-310B	ID-C112GXB	0.003mm	1.5N or less

DIMENSIONS

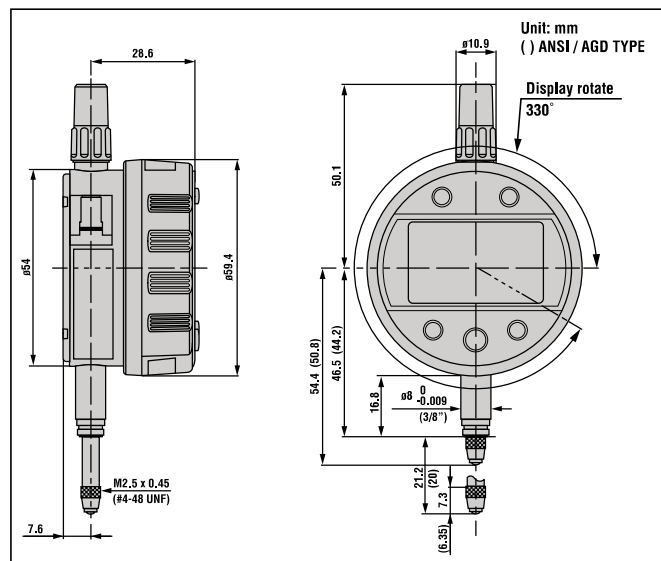

ABSOLUTE Digimatic Indicator ID-C

SERIES 543 — With Green/Red LED and Go/No-go Signal Output Function

ABSOLUTE®
Absolute System Patented by MITUTOYO



FEATURES

- With the max./min. value holding function, the signal ID-C can output the go/no-go judgment result against the peak values set. Substitute for the mechanical/electrical contact, the judgment is carried out by calculating the measurement data obtained. This provides high reliability with no deterioration of the contact point and volume adjustment.
- The signal can be output to an external device such as a sequencer through the NPN open-collector.
- The go/no-go judgment result is also indicated by the green/red LED and the "<, O, >" signs on LCD.
- Employing the ABSOLUTE linear encoder, the Signal ID-C always displays the spindle Absolute Position from the origin when powered up.
- The Signal ID-C achieves the IP54 protection level to resist dust and contaminants for safe operation in harsh machine shop environments.
- The high-speed detector measures 100 times per second.
- Analog Bar



SPECIFICATIONS

Inch/Metric		Stem dia. 3/8" #4-48 UNF Thread		ISO/JIS type	ANSI/AGD type
Resolution	Range	Order No. (w/ lug, flat-back)	Model	Accuracy	Measuring force
.00005/.0001/.0005" 0.001/0.01mm	.5" / 12.7mm	543-352 543-352B	ID-C112JEX(B)	±.00010/0.003mm	2.5N or less

Inch/Metric		Stem ø 8mm, M2.5 x 0.45 Thread		ISO/JIS type	ANSI/AGD type
Resolution	Range	Order No. (w/ lug, flat-back)	Model	Accuracy	Measuring force
.00005/.0001/.0005" 0.001/0.01mm	.5" / 12.7mm	543-351 543-351B	ID-C112JMX(B)	±.00010/0.003mm	2.5N or less

Metric		Stem ø 8mm, M2. x 0.45 Thread		ISO/JIS type	ANSI/AGD type
Resolution	Range	Order No. (w/ lug, flat-back)	Model	Accuracy	Measuring force
0.001/0.01mm	12.7mm	543-350 543-350B	ID-C112JX(B)	0.003mm	2.5N or less

DIMENSIONS

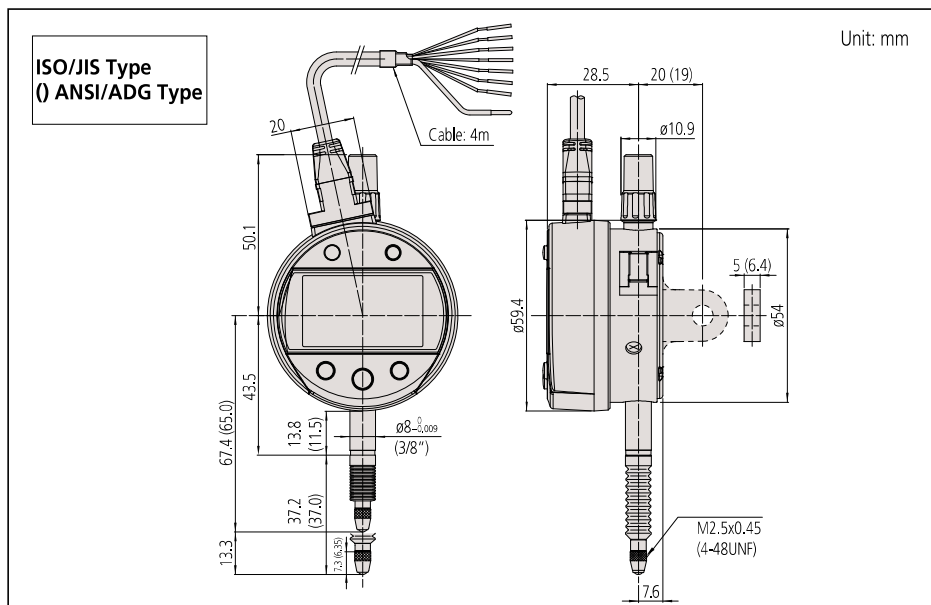

Technical Data

Accuracy: Refer to the list of specifications
 Resolution: 0.001mm, .00005"/0.001mm
 Display: LCD
 Length standard: ABSOLUTE electrostatic capacitance type linear encoder
 Max. response speed: Unlimited
 Measuring force: 2.5N or less
 Power supply: DC 5-24V±10%
 Dust/Water protection level: IP54

Function

Data output (-NG/OK/NG signal, NPN open collector), Remote control (hold-preset, preset-recall, zero-set), Origin-Set, Preset (up to 3 values), Zero-Set, Analog-Bar, go/no-go judgment, Max/Min/Runout value holding, Counting direction switching, Power ON/OFF, inch/mm conversion (on inch/metric models only), calibration mode

Internal calculations using the simple formula of $F(x) = Ax$ are available.

Alarm: Low voltage, Counting value composition error, Overflow error, Tolerance limit setting error

Optional Accessories

- 902011:** Spindle lifting lever* (ISO/JIS type)
- 902794:** Spindle lifting lever* (ANSI/AGD type)
- 540774:** Spindle lifting cable* (Stroke: .4" / 10mm)
- 125317:** Rubber boot
- Backs (See page F-33.)
- Contact points (See page F-34.)

21EAA194: Connecting Cable (1m)**

21EAA190: Connecting Cable (2m)**

21EZA345A: Digimatic Power Supply Unit**

*When using the spindle lifting lever/cable, IP54 is not guaranteed.
 ** Used only for calibration mode and for automated testing with an i-Checker

Output pattern

Wire	- NG	OK	+ NG	Composition error
Orange (- NG)	Low	High	High	High
Green (OK)	High	Low	High	High
Brown (+ NG)	High	High	Low	High
LED	Red	Green	Red	Red (blinking)
LCD	<	O	>	"x.xx" indication

I/O Specifications

Wire	Signal	I/O	Description
Black	- V (GND)	—	Connected to minus (-) terminal
Red	+ V (GND)	I	Power supply (5-24VDC)
Orange	- NG	O	Tolerance judgment result
Green	OK	O	output: Only the terminal corresponding to a judgment result is set to the below level.
Brown	+ NG	O	
Yellow	PRESET_RECALL ZERO	I	External input terminal: If the relevant terminal is set to the low level, its signal becomes true.
Blue	PEAK_START	I	
Shield	FG	—	Connected to GND

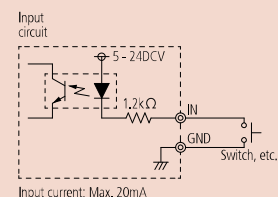
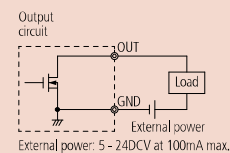



Technical Data

Accuracy: Refer to the list of specifications
 Resolution: 0.0005mm/0.001mm or .00002"/.00005"/.0001"/0.0005mm/0.001mm
 Display: LCD
 Length standard: Linear encoder
 Max. response speed: 1000mm/s
 Measuring force: 2.0N/2.5N* or less (*60mm range models)
 Power supply: 6V DC (via AC adaptor)

Function

Origin-set/Preset, Zeroset, go/no-go judgment, Max/Min value hold, Runout measurement, Resolution switching, Counting direction switching, Power ON/OFF, Data output, inch/mm conversion (on inch/metric models only)
 Alarm: Low voltage, Counting value composition error, Overflow error, Tolerance limit setting error

Standard Accessories

06AEG180JA: AC Adapter 120V
137693: Lifting Lever

Optional Accessories

936937: SPC cable (40" / 1m)
965014: SPC cable (80" / 2m)
21EAA131: RS-232C cable (80" / 2m)
21EZA099: Remote controller
540774: Spindle lifting cable (stroke: .4" / 10mm)
21EZA101: Spindle lifting knob
264-504-5A: Digimatic Min-processor DP-1VR
21EZA152A: FREE PARAMETER SETTING SOFTWARE
 ———: Backs (See page F-33.)
 ———: Contact points (See page F-34.)

Application

Difference/Runout measurement

Example: Indicator travel from points A to D

Difference (or Total Runout) is displayed as A. Dimensions B (maximum value) and C (minimum value) can be recalled from memory with a simple key sequence.

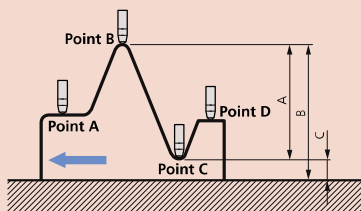

Order No.	A	B	C	D	E
543-561A	251.3	47.3	30.48	60	7.3
543-562A	250.35	46.35	30.48	60	6.35
543-563A	311.3	77.3	60.96	90	7.3
543-564A	310.35	76.35	60.96	90	6.35

Digimatic Indicator ID-H

SERIES 543 — High-Accuracy and High-Functional Type

FEATURES

- This new generation digital indicator offers the excellent accuracy and functionality expected from this class of indicator. Take advantage of its high accuracy backed by 0.5μm / .00002" resolution, remote control functionality via a handheld controller (or an RS-232C interface) and easy runout measurements with the analog bar display.
- The maximum, minimum, or runout value can be displayed during measurement.
- Go/no-go judgment is performed by setting the upper and lower tolerances. If a judgment result is out of tolerance, the display backlighting changes from green to red, so tolerance judgment can be made at a glance.
- With SPC data output.
- With RS-232C input/output.



21EZA099
Remote controller (optional)

543-561A

543-564A

SPECIFICATIONS

Inch/Metric Stem dia. 3/8" #4-48 UNF Thread

Resolution	Range	Order No.	Model	Accuracy
.00002", .00005", .0001", 0.0005mm, 0.001mm	1.2" / 30.4mm	543-562A	ID-H530E	0.0015mm
	2.4" / 60.9mm	543-564A	ID-H560E	0.0025mm

Metric Stem ø 8mm M2.5 X 0.45 Thread

Resolution	Range	Order No.	Model	Accuracy
0.0005mm, 0.001mm	30.4mm	543-561A	ID-H530	0.0015mm
	60.9mm	543-563A	ID-H560	0.0025mm

DIMENSIONS

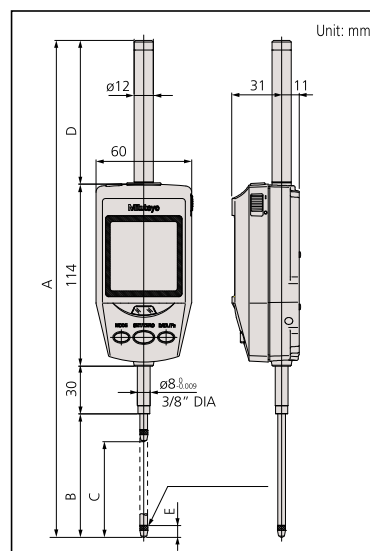

Tolerance judgment



Analog bar display



Max/Min value measurement



Runout measurement



Resolution switching



ABSOLUTE Digimatic Indicator ID-F

SERIES 543 — With Back-lit LCD



FEATURES

- With ABSOLUTE linear encoder technology, once the measurement reference point has been set it, will not be lost when the power is turned on.
- Go/no-go judgment is performed by setting the upper and lower tolerances. If a judgment result is out of tolerance, the display backlighting changes from green to red, so tolerance judgment can be made at a glance.
- The maximum, minimum, or runout value can be displayed during measurement.
- An analog bar indicator has been integrated to handle upper/lower limit approaching and zero approaching. The display range can be changed.
- With SPC data output.

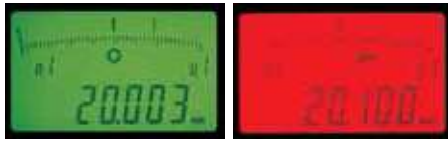

SPECIFICATIONS

Inch/Metric Stem dia. 3/8" #4-48 UNF Thread

Resolution	Range	Order No.	Model	Accuracy
.00005", .0001", .0005", .001", 0.001mm, 0.01mm	1" / 25.4mm	543-552A	ID-F125E	.00012"
	2" / 50.8mm	543-558A	ID-F150HE	.00012"

Metric Stem \varnothing 8mm M2.5 X 0.45 Thread

Resolution	Range	Order No.	Model	Accuracy
0.001mm, 0.01mm	25mm	543-551A	ID-F125	0.003mm
	50mm	543-557A	ID-F150H	0.003mm

DIMENSIONS

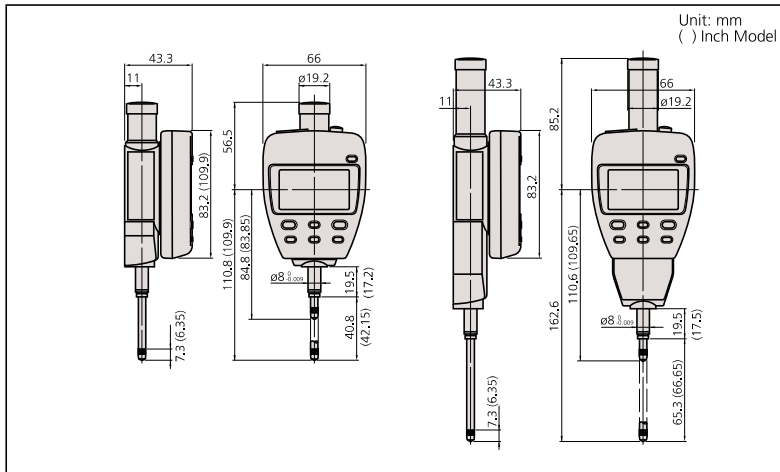

Technical Data

Accuracy: Refer to the list of specifications
 Resolution: 0.01mm/0.001mm or .0005"/.0001"/.0005"
 / .001"/0.001mm/0.01mm
 Display: LCD
 Length standard: ABSOLUTE electrostatic capacitance type
 linear encoder
 Max. response speed: Unlimited
 Measuring force: 1.8N/2.3N* or less (*50mm range models)
 Power supply: 9V DC (via AC adaptor)

Function

Origin-set/Preset, Zeroset, Go/no-go judgment, Max/Min value hold, Runout measurement, Resolution switching, Counting direction switching, Power ON/OFF, Data output, inch/mm conversion (on inch/metric models only)
 Alarm: Low voltage, Counting value composition error, Overflow error, Tolerance limit setting error

Standard Accessories

06AEG302JA: AC Adapter 120v
137693: Lifting Level

Optional Accessories

936937: SPC cable (40" / 1m)
965014: SPC cable (80" / 2m)
540774: Spindle lifting cable (stroke: .4" / 10mm)
02ACA571: Auxiliary spindle spring for 25mm/1" models*
02ACA773: Auxiliary spindle spring for 50mm/2" models*
264-504-5A: Digimatic Min-processor DP-1VR
543-004-1: Digimatic presetter
 _____ Backs (See page F-33.)
 _____ (See page F-34.)

*Required when orienting the indicator upside down.

Application

Difference/Runout measurement

Example: Indicator travel from points A to D

Difference (or Total Runout) is displayed as A. Dimensions B (maximum value) and C (minimum value) can be recalled from memory with a simple key sequence.

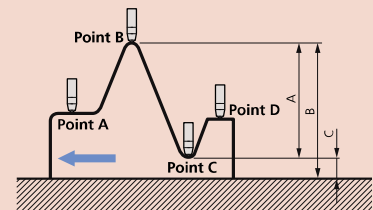



Technical Data

Accuracy: Refer to the list of specifications
 Resolution: 0.01mm, 0.01mm/0.001mm, .0005"/0.01mm or .0005"/.00005"/0.01mm/0.001mm
 Display: LCD
 Length standard: ABSOLUTE electrostatic capacitance-type linear encoder
 Max. response speed: Unlimited
 Measuring force: 2.5N (2.0N: Back plunger type)
 Battery: SR44 (1 pc.), **938882**
 Battery life: Approx. 7000 hours under normal use
 Dust/Water protection level: IP66

Function

Zero-setting, Presetting, Direction switching, Tolerance judgment, Display hold, Data output, inch/mm conversion (on inch/metric models only)
 Alarm: Low voltage, Counting value composition error, Overflow error, Tolerance limit setting error

Optional Accessories

- 21EZA105:** Lifting knob (for ISO/JIS model, ID-N only)
- 21EZA150:** Lifting knob (for AGD model, ID-N only)
- 21EZA145:** Lug (for JIS/ISO model)
- 21EZA146:** Lug (for AGD model)
- 02ACA376:** Rubber boot (for ID-N, NBR)
- 238774:** Rubber boot (for ID-N, silicon)
- 125317:** Rubber boot (for ID-B, NBR)
- 21EAA212:** Rubber boot (for ID-B, silicon)
- 21EAA194:** SPC cable (40" / 1m)
- 21EAA190:** SPC cable (80" / 2m)
- 21EAA210:** Bifurcated connecting cable with zero-setting terminal (40" / 1m)
- 21EAA211:** Bifurcated connecting cable with zero-setting terminal (80" / 2m)
- : Contact points (See page F-34.)



ABSOLUTE Digimatic Indicator ID-N / B

SERIES 543 — With Dust/Water Protection Conforming to IP66

FEATURES

- Proven ABSOLUTE sensor.
- Rated to IP66 water- and dust-proofing standard, and oil resistance improved.
- Slim body design is advantageous for multi-point measurements.
- Improvement in workability with the LCD readout-rotation function.
- Back plunger design (ID-B).
- Built-in tolerance judgment function.
- Switchable resolution.
- Waterproof data output connector.
- Built-in hold/preset function.



Slim type ID-N
543-576

Back plunger type ID-B
543-586



ID-B Digimatic Indicators

SPECIFICATIONS

Metric		Stem ø 8mm M2.5 X 0.45 Thread			
Resolution	Range	Order No.	Model No.	Accuracy	Measuring Force
0.01mm	5.0mm	543-580	ID-B1005	0.02mm	2.0N or less
0.001mm	5.0mm	543-585	ID-B105	0.003mm	2.0N or less

Inch / Metric		Stem dia. 3/8" #4-48 UNF Thread			
Resolution	Range	Order No.	Model No.	Accuracy	Measuring Force
.0005" / 0.01mm	.22" / 5.6mm	543-581	ID-B1005E	.0008" / 0.02mm	2.0N or less
.0005" / 0.01mm .00005" / 0.001mm	.22" / 5.6mm	543-586*	ID-B105E	.00012" / 0.003mm	2.0N or less

* Switchable resolution

ID-N Digimatic Indicators

Metric		Stem ø 8mm M2.5 X 0.45 Thread			
Resolution	Range	Order No.	Model No.	Accuracy	Measuring Force
0.01mm	5.0mm	543-570	ID-N1012	0.02mm	2.0N or less
0.001mm / 0.01mm	5.0mm	543-575	ID-N112	0.003mm	2.0N or less

Inch / Metric		Stem dia. 3/8" #4-48 UNF Thread			
Resolution	Range	Order No.	Model No.	Accuracy	Measuring Force
.0005" / 0.01mm	.5" / 12.7mm	543-571	ID-N1012E	.0008" / 0.02mm	2.0N or less
.0005" / 0.01mm .00005" / 0.001mm	.5" / 12.7mm	543-576*	ID-N112E	.00012" / 0.003mm	2.0N or less

* Switchable resolution

DIMENSIONS AND MASS

