

Vernier Caliper

SERIES 531 — with Thumb Clamp

FEATURES

- The slider moves only when the spring loaded thumb clamp is depressed.
- Can measure OD, ID, depth and steps
- Supplied with vinyl holster in fitted carton.

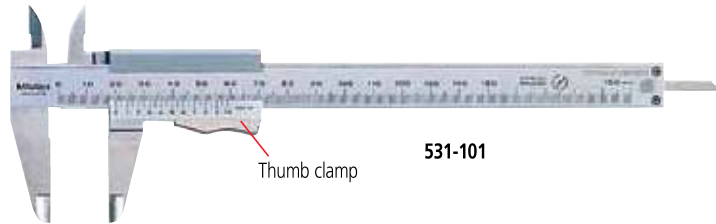

531-101

Thumb clamp

SPECIFICATIONS

Metric

Range	Order No.	Accuracy	Graduation	Remarks
0 - 150mm	531-101	±0.05mm	0.05mm	—
0 - 200mm	531-102	±0.05mm	0.05mm	—
0 - 300mm	531-103	±0.08mm	0.05mm	—

Metric/Inch with metric/inch dual scale

Range	Order No.	Accuracy	Graduation		Remarks
			Lower Scale	Upper Scale	
0 - 150mm / 0 - 6"	531-122	±0.05mm	0.05mm	1/128"	with inch/mm conversion label
0 - 150mm / 0 - 6"	531-128	±0.03mm	0.02mm	.001"	High-accuracy model
0 - 200mm / 0 - 8"	531-108	±0.05mm	0.05mm	1/128"	—
0 - 200mm / 0 - 8"	531-129	±0.03mm	0.02mm	.001"	High-accuracy model
0 - 300mm / 0 - 12"	531-109	±0.08mm	0.05mm	1/128"	—
0 - 300mm / 0 - 12"	531-112	±0.04mm	0.02mm	.001"	High-accuracy model

DIMENSIONS AND MASS

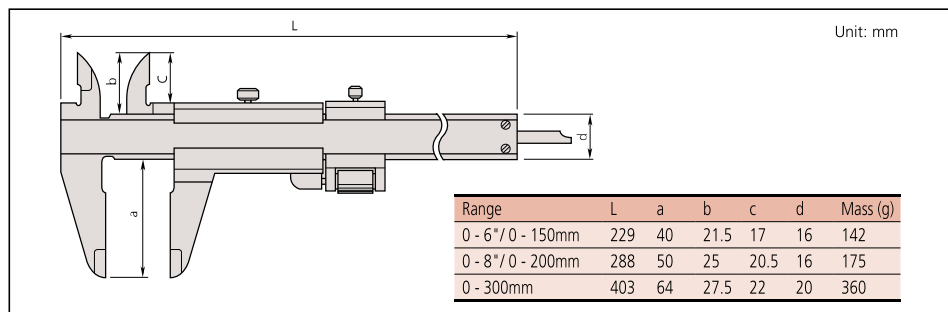

Measurement Applications



OD measurement

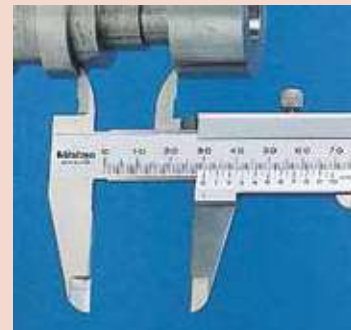

ID measurement

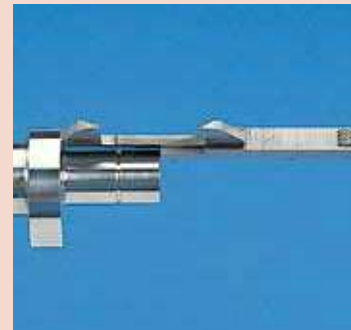

Step measurement



Depth measurement