

E7 Drive Parameter Access Technical Manual



Warnings and Cautions

This Section provides warnings and cautions pertinent to this product, that if not heeded, may result in personal injury, fatality, or equipment damage. Yaskawa is not responsible for consequences of ignoring these instructions.

WARNING

YASKAWA manufactures component parts that can be used in a wide variety of industrial applications. The selection and application of YASKAWA products remains the responsibility of the equipment designer or end user. YASKAWA accepts no responsibility for the way its products are incorporated into the final system design. Under no circumstances should any YASKAWA product be incorporated into any product or design as the exclusive or sole safety control. Without exception, all controls should be designed to detect faults dynamically and to fail safely under all circumstances. All products designed to incorporate a component part manufactured by YASKAWA must be supplied to the end user with appropriate warnings and instructions as to that part's safe use and operation. Any warnings provided by YASKAWA must be promptly provided to the end user. YASKAWA offers an express warranty only as to the quality of its products in conforming to standards and specifications published in the YASKAWA manual. **NO OTHER WARRANTY, EXPRESS OR IMPLIED, IS OFFERED.** YASKAWA assumes no liability for any personal injury, property damage, losses, or claims arising from misapplication of its products.

WARNING

- Read and understand this manual before installing, operating, or servicing this drive. All warnings, cautions, and instructions must be followed. All activity must be performed by qualified personnel. The drive must be installed according to this manual and local codes.
- Do not connect or disconnect wiring while the power is on. Do not remove covers or touch circuit boards while the power is on. Do not remove or insert the digital operator while power is on.
- Before servicing, disconnect all power to the equipment. The internal capacitor remains charged even after the power supply is turned off. Status indicator LEDs and Digital Operator display will be extinguished when the DC bus voltage is below 50 VDC. To prevent electric shock, wait at least 5 minutes after all indicators are OFF and measure DC bus voltage and verify that it is at a safe level.
- Do not perform a withstand voltage test on any part of the unit. This equipment uses sensitive devices and may be damaged by high voltage.
- The drive is not suitable for circuits capable of delivering more than the specified RMS symmetrical amperes. Install adequate branch short circuit protection per applicable codes. Refer to the specification. Failure to do so may result in equipment damage and/or personal injury.
- Do not connect unapproved LC or RC interference suppression filters, capacitors, or over voltage protection devices to the output of the drive. Capacitors may generate peak currents that exceed drive specifications.
- To avoid unnecessary fault displays, caused by contactors or output switches placed between drive and motor, auxiliary contacts must be properly integrated into the control logic circuit.
- YASKAWA is not responsible for any modification of the product made by the user, doing so will void the warranty. This product must not be modified.
- Verify that the rated voltage of the drive matches the voltage of the incoming power supply before applying power.
- To meet CE directives, proper line filters and proper installation are required.
- Some drawings in this manual may be shown with protective covers or shields removed, to describe details. These must be replaced before operation.
- Observe Electrostatic Discharge Procedures when handling the drive and drive components to prevent ESD damage.
- The attached equipment may start unexpectedly upon application of power to the drive. Clear all personnel from the drive, motor and machine area prior to applying power. Secure covers, couplings, shaft keys, machine beds and all safety equipment before energizing the drive.
- Do not attempt to disassemble this unit. There are no user serviceable parts. Disassembling this unit will void any and all warranties.

Introduction

This manual is intended as a parameter access quick reference guide for the Yaskawa model E7 drive. It describes how to connect the E7 drive to an RS232, RS422 or RS485 network and access parameters and their values. It lists the available parameters, their addresses, limits, available selections and default values. Refer to the *E7 Drive Programming Manual* for detailed parameter information.

This document pertains to the E7 drive. In this document, the word “inverter”, “ac drive” and “drive” may be used interchangeably.

For details on installation and operation of the E7 drive, refer to the *E7 Drive User Manual*. All manuals and support files are available on the CD that came with the E7 drive and are also available for download at www.drives.com.

E7 Drive User Manual document reference **TM.E7.01**

E7 Drive Programming Manual document reference **TM.E7.02**

E7 Drive Parameter Access Technical Manual document reference **TM.E7.11**

GPD is a trademark of Yaskawa, Inc.

MODBUS[®] is a registered trademark of Schneider Automation, Inc.

All trademarks are the property of their respective owners.

Table of Contents

Chapter 1 Connections.....	1-1
Connection Check Sheet.....	1-3
Verify Operation.....	1-5
Serial Network Connections.....	1-6
Communications Parameters.....	1-8
Operation Method and Frequency Reference.....	1-10
Verify Communications.....	1-11
Chapter 2 Message Formats.....	2-1
Protocol.....	2-3
Read Multiple Registers – Function Code 03H.....	2-4
Write Single Register – Function Code 06H.....	2-6
Loop-Back Test – Function Code 08H.....	2-8
Write Multiple Registers – Function Code 10H.....	2-10
No Response.....	2-12
Error Codes.....	2-12
CRC-16 Calculations.....	2-13
Chapter 3 Troubleshooting.....	3-1
General Information.....	3-3
RS232 Communications.....	3-4
RS422/RS485 Communications.....	3-6
RS422/RS485 Self-Test.....	3-9
Chapter 4 E7 Drive Parameters.....	4-1
Command Registers (Read / Write).....	4-3
Simultaneous Broadcast Registers (Write only).....	4-4
Monitor Registers (Read only).....	4-5
Parameters (Read/Write).....	4-11
ENTER/ACCEPT Command (Write Only).....	4-21
Parameter Dependencies.....	4-22
Chapter 5 User Notes.....	5-2
Parameter Record.....	5-4
Notes.....	5-11
Hex/Dec Conversion Table.....	5-12

This page intentionally left blank.

Chapter 1 Connections

This chapter describes how to connect the E7 drive to an RS232, RS422 or RS485 network

Connection Check Sheet.....	1 – 3
Verify Operation	1 - 5
Serial Network Connections	1 - 6
Communications Parameters	1 - 8
Operation Method and Frequency Reference	1 – 10
Verify Communications.....	1 - 11

This page intentionally left blank

Connection Check Sheet

The following is a quick reference guide to connect and configure the E7 drive for serial communications. Make a copy of this page and check-off each item as it is completed. For detailed information please refer to the detailed sections that follow.

- 1:** Unpack the E7 drive and verify that all components are present and undamaged.
- 2:** Connect power to the E7 drive and verify that the E7 drive functions correctly. This includes running the E7 drive from the operator keypad. Refer to the *E7 Drive User Manual* for information on connecting and operating the E7 drive.
- 3:** Remove power from the E7 drive and wait for the charge lamp to be completely extinguished. Wait at least five additional minutes for the E7 drive to be completely discharged. Measure the DC bus voltage and verify that it is at a safe level.
- 4:** Connect the E7 drive to an RS232 network.
 - 4.1:** Remove the E7 drive's operator keypad.
 - 4.2:** Connect the RJ45 port on the front of the E7 drive to the controller serial port. Use a DB9 to RJ45 adapter with a standard Ethernet CAT-5 patch cable or use Yaskawa cables, part numbers UWR00468-1 or UWR00468-2. **Do NOT connect this cable to an Ethernet port** on the controller, as damage to the controller and/or E7 drive may result. Refer to *Figure 1.2 – RS232 Connections*.
 - 4.3:** Verify that the controller communications parameters match the E7 drive's communications parameters. Refer to *Table 1.1 – RS232 (RJ45 port) Communications' Parameters* for a list of default E7 drive communications parameters.
 - 4.4:** Reapply power to the E7 drive.
- 5:** Connect the E7 drive to an RS422/485 network.
 - 5.1:** Remove the E7 drive's terminal cover.
 - 5.2:** Connect the controller to the S+/S- and R+/R- terminals on the E7 drive's terminal block as shown in *Figure 1.3 – RS422/485 Connections*.
 - 5.3:** If this device is either the first or last device on the network, set the network termination, S1, to the ON position.
 - 5.4:** Reapply power to the E7 drive.
 - 5.5:** Set the E7 drive communication parameters to match those of the controller. Refer to *Table 1.2 – Baud Rate*, *Table 1.3 – Parity* and *Table 1.4 – RTS*.
 - 5.6:** Set the node address of the E7 drive.
- 6:** Verify that the E7 drive and controller are communicating and that the exchanged data is valid.

This page intentionally left blank.

Verify Operation

Connect power to the E7 drive and verify that the E7 drive functions properly. This includes running the E7 drive from the operator keypad. Refer to the *E7 Drive User Manual*, for information on connecting and operating the E7 drive.

Remove power from the E7 drive and wait for the charge lamp to be completely extinguished. Wait at least five additional minutes for the E7 drive to be completely discharged. Measure the DC bus voltage and verify that it is at a safe level.

Remove the operator keypad and terminal cover.

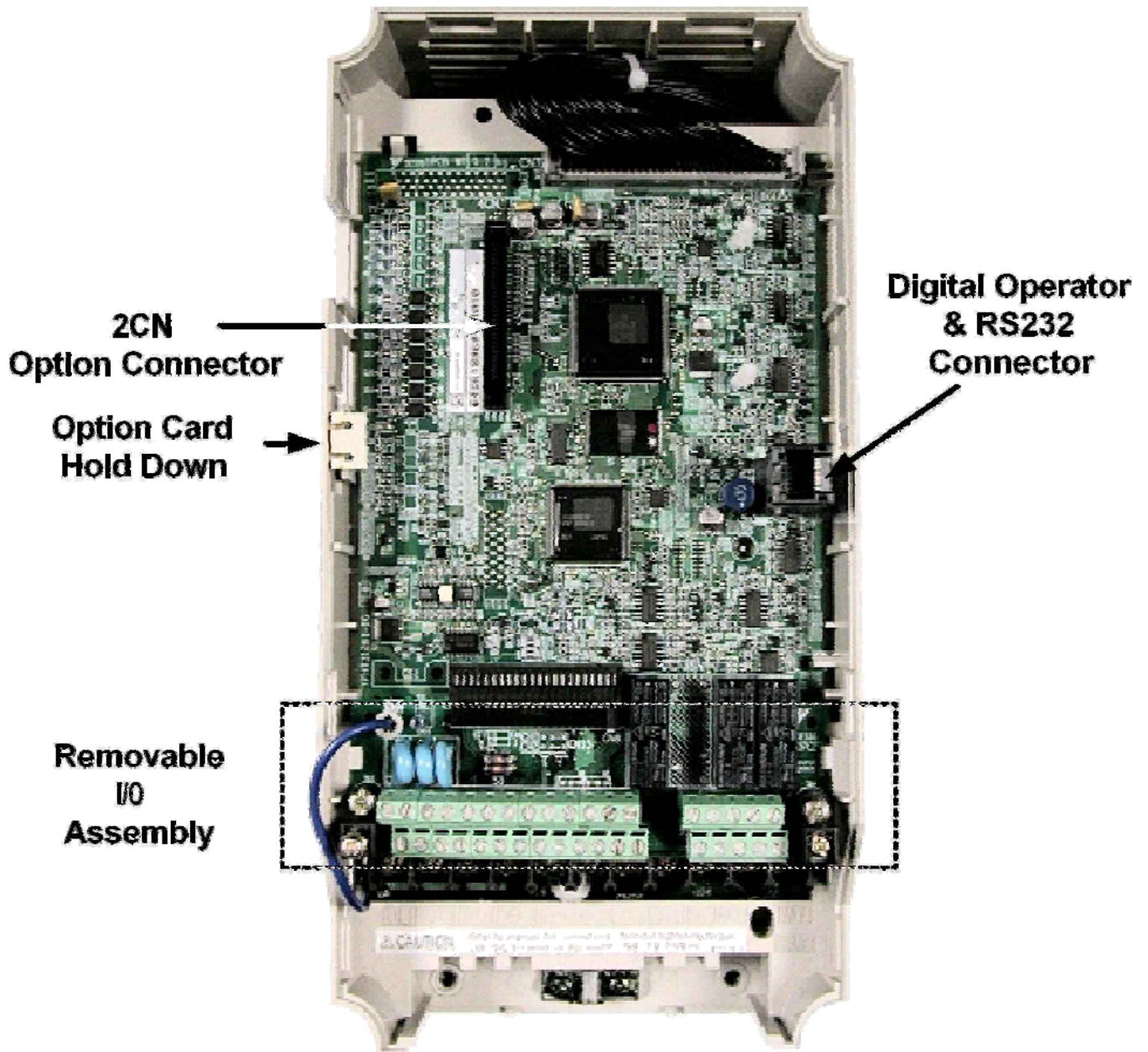

Figure 1.1 – Connector Diagram

Serial Network Connections

The following describes how to connect the E7 drive to an RS232, RS422 and RS485 serial network. For detailed information please refer to the appropriate sections of this manual or the *E7 Drive User Manual*.

► RS232 Networks

The RS232 network is a single ended network with limited data transmission rates and cable lengths. The E7 drive RS232 data transmission is fixed at 9600bps, no parity, 8 data bits and 1 stop bit. The maximum cable length is 50 ft (16m). It is recommended that Yaskawa cables, UWR00468-1 or UWR00468-2 be used. The UWR00468-1 cable can be used for both standard RS232 communications and for downloading control software.

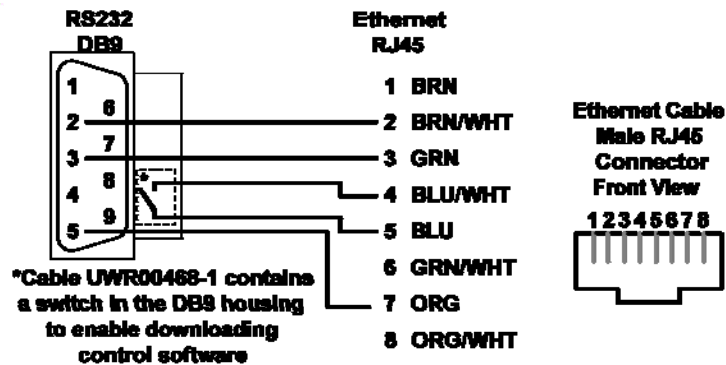

Figure 1.2 – RS232 Network Connection

► RS422/RS485 4-Wire Networks

RS422/RS485 4-wire networks allow for longer cable lengths, maximum 4000 ft (1200m), and are more immune to noise than RS232 networks. While RS422/RS485 4-wire may be used as multi-drop networks, however, single-ended networking is recommended. All RS422/RS485 4-wire communication is half-duplex. Since each device is separately connected, set the Termination Resistor S1 to ON (slide the switch to the right) on each device.

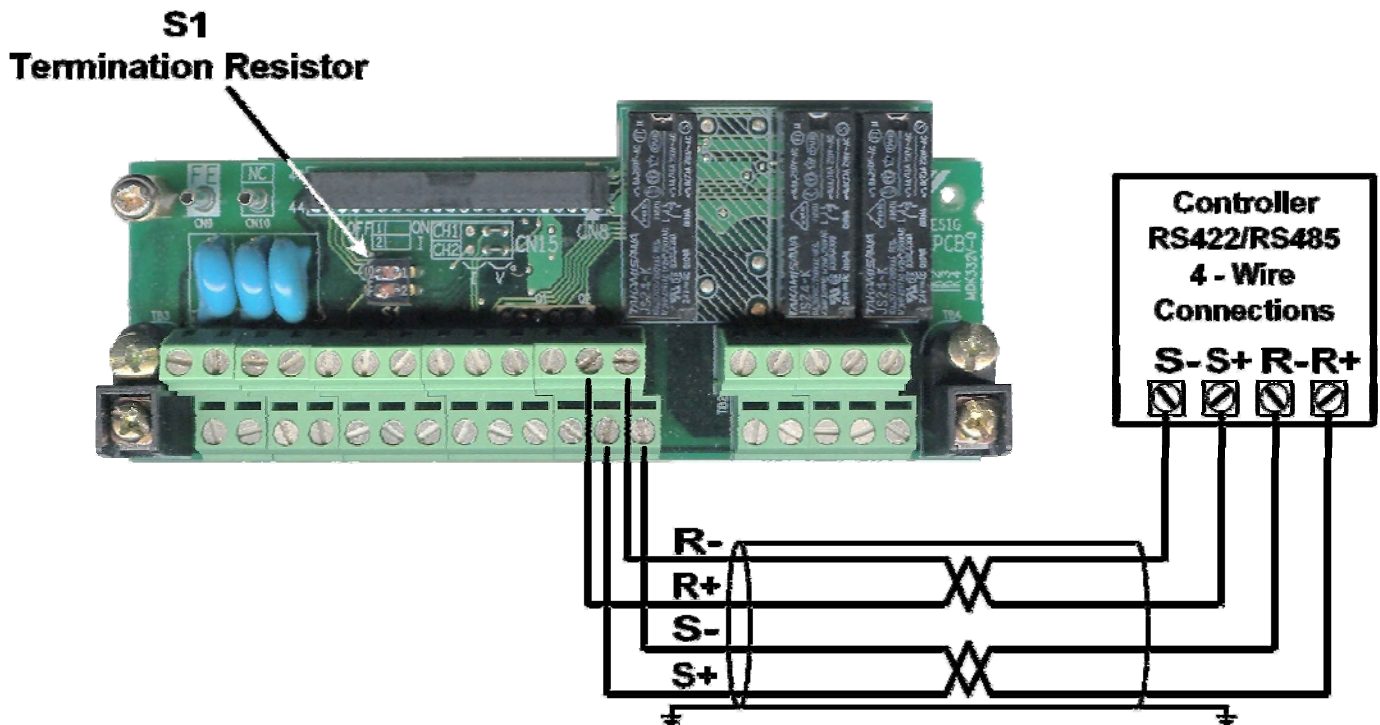

Figure 1.3 – RS422/RS485 4-Wire Network Connection

► RS485 2-Wire Networks

RS485 2-wire networks can be either single or multi-drop networks, with each slave device on the network assigned a unique node address. A maximum of 31 devices may reside on any network segment before a repeater is required. Terminating resistors must be installed on the first and last devices on each network segment. The maximum segment length is 4000ft (1200m). All RS485 communications are half-duplex.

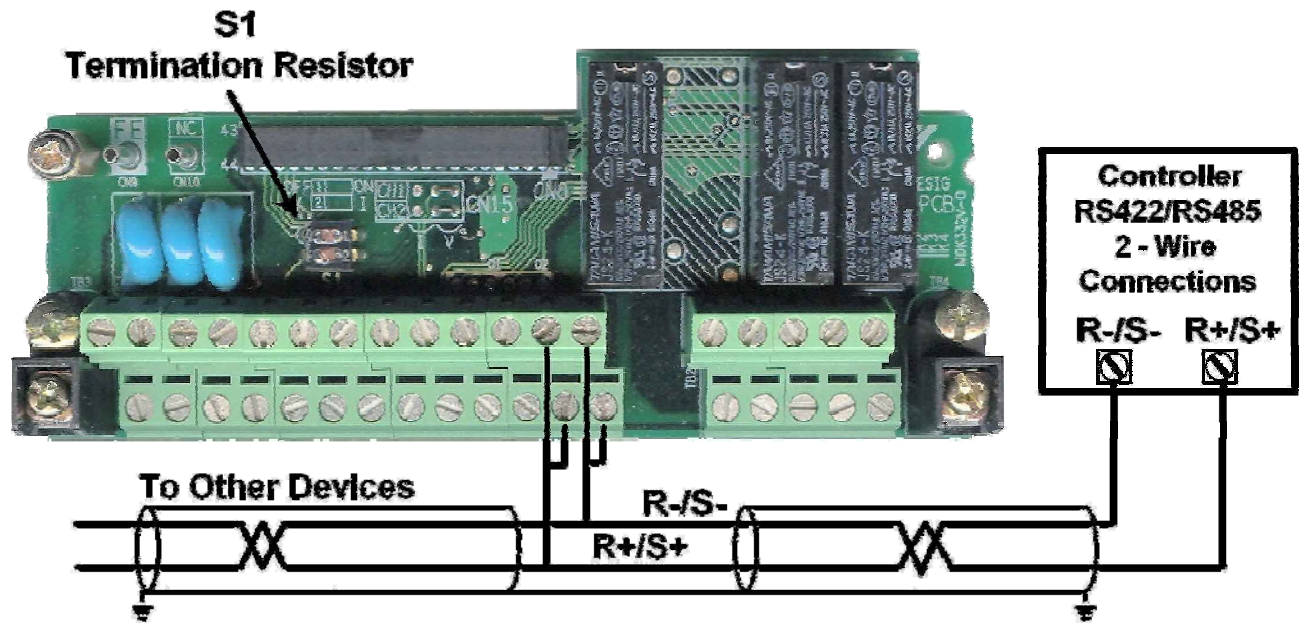

Figure 1.4 – RS485 2-Wire Network Connection

Communications Parameters

These communications parameters affect serial communications through RS232, RS422 and RS485. The RS232 communications parameters cannot be changed. Also, the node address is ignored when communicating via RS232.

All serial communications parameters can only be changed via the operator keypad.

► RS232 Communications

The RS232 communications' parameters are fixed at the values shown below. Although the node address is ignored, a node address of 1 is typically used by the master when communicating to the E7 drive in this method.

Value	Description
Baud rate	9600
Parity	None
Stop Bits	1
Node Address	N/A

► RS422/RS485 Communications

■ Node Address – H5-01

The node address is set through E7 drive parameter H5-01. When communicating via RS422 or RS485, a unique node address between 0 and 20h (32 dec), inclusive, must be entered. The default E7 drive address is 1Fh (31 dec). The address is always entered as a hexadecimal number (refer to the conversion chart in Chapter 4). Address 0 is typically reserved for global messages.

■ Baud rate – H5-02

Select the baud rate that matches the controller's serial configuration. The default baud rate is 9600 (3).

Value	Description
0	1200
1	2400
2	4800
3	9600
4	19200

■ Parity – H5-03

Select the parity that matches the controller's serial configuration. The default parity is None (0).

Value	Description
0	None
1	Even
2	Odd

■ Serial Communications Send Delay – H5-06

A delay can be inserted before the E7 drive responds to a command message. This allows for slower communications devices to switch transceiver state in order to get ready to receive a message. A value of 5 ~ 65 ms can be inserted, 5ms being the default.

■ RTS Control – H5-07

This parameter determines whether RTS is continually asserted (disabled) or asserted only during send (enabled). RTS must be enabled for use with RS422/485 communications. The default is disabled (0).

Table 1.4 – RTS – Parameter H5-07	
Value	Description
0	Disable (always ON)
1	Enable (ON only during send)

■ Communication Method – H5-08

This parameter determines which communication protocol is used. This manual deals with the Memobus (MODBUS RTU) protocol. The default values is Memobus (0).

Table 1.5 – RTS – Parameter H5-08	
Value	Description
0	Memobus(Modbus)
1	N2 (Metasys)
2	FLN (APOGEE)

Operation Method and Frequency Reference

The Run/Stop and Frequency Reference commands can originate from serial communication, the operator keypad, external terminals, or an option card. Parameter b1-01 (Operation Method Selection) allows the selection of the origin of the Run/Stop command. Parameter b1-02 (Reference Selection) allows the selection of the origin of the Frequency Reference command. The Run/Stop and Frequency Reference commands may have different origins. For example, the Run/Stop command may be set to External Terminals (b1-01 = 1) while the Frequency Reference command may be set Serial Communications (b1-02=2).

► Operation Method

Table 1.5 – Operation Method Selection	
b1-01	Operation Method Selection (Run/Stop)
0	Operator keypad
1	External Terminals (Default setting is 1)
2	Serial Communication
3	Option Card

► Frequency Reference Source

Table 1.6 – Frequency Reference Source Selection	
b1-02	Frequency Reference Selection
0	Operator keypad
1	External Terminals (Default setting is 1)
2	Serial Communications (Parameter Access)
3	Option Card

Verify Communications

The following is a quick reference guide for serial communications to the E7 drive. Make a copy of this page and check-off each item as it is completed. For detailed information please refer to the detailed sections that follow.

1: RS232 communication

1.1: Verify that the correct cable is used to connect the controller to the E7 drive.

1.2: Verify that the controller is set for RS232 communications and that the communication's cable is connected to the correct communications port.

1.3: Record the controller communications' parameters

Baud Rate _____ **Parity** _____ **Data Bits** _____ **Stop Bits** _____ **Protocol** _____

1.4: Record the E7 drive communications' parameters (H5-02, H5-03, H5-07, H5-08)

Baud Rate _____ **Parity** _____ **Data Bits** _____ **Stop Bits** _____ **Protocol** _____

1.5: Verify that the communications' parameters match.

2: RS422/RS485 communications.

2.1: Verify that the E7 drive is connected correctly.

2.2: Verify that the controller is set for RS422/RS485 communications and that the communication's cable is connected to the correct communications' port.

2.3: Record the controller communications' parameters

Baud Rate _____ **Parity** _____ **Data Bits** _____ **Stop Bits** _____ **Protocol** _____

2.4: Record the E7 drive communications' parameters (H5-01, H5-02, H5-03, H5-07, H5-08)

Baud Rate _____ **Parity** _____ **Data Bits** _____ **Stop Bits** _____ **Protocol** _____

2.5: Verify that the communications' parameters match.

2.6: Verify that parameter H5-07 (RTS) is set to enable.

2.7: Verify that parameter H5-01 (Node Address) is set to the correct, unique, hexadecimal value and that it matches the node address required by the controller.

Controller Node Address _____ **E7 Drive Node Address** _____

3: Send a command message to the E7 drive from the controller and verify the data of the command and response messages.

3.1: Verify the contents of the command message.

[] [] [] [] [] [] [] [] [] []
[] [] [] [] [] [] [] [] [] []
[] [] [] [] [] [] [] [] [] []
[] [] [] [] [] [] [] [] [] []

3.2: Verify the contents of the response message.

[] [] [] [] [] [] [] [] [] []
[] [] [] [] [] [] [] [] [] []
[] [] [] [] [] [] [] [] [] []
[] [] [] [] [] [] [] [] [] []

Notes:

This page intentionally left blank

Chapter 2 Message Formats

This chapter provides information on the message (telegram) contents and configuration.

Protocol	2 - 3
Read Multiple Registers – Function Code 03H.....	2 – 4
Write Single Registers – Function Code 06H	2 – 6
Loop-Back Test – Function Code 08H.....	2 - 8
Write Multiple Registers – Function Code 10H	2 – 10
No Response.....	2 – 12
Error Codes	2 - 12
CRC Calculations.....	2 - 13

This page intentionally left blank

Protocol

The parameter access method supported by the Yaskawa E7 drive is a subset of the MODBUS[®] communication protocol. The E7 drive supports functions 3, 6, 8 and 10h. The message format varies depending upon the function code of the message. For each function code, there is a command message from the master and a response message from the slave. The following sections review the format of the command and response messages for each function.

► Message Functions Supported

The following table lists the function codes available and their minimum and maximum lengths.

Function Code	Function	Command Message		Response Message (Normal)	
		min. (bytes)	max. (bytes)	min. (bytes)	max. (bytes)
3h (3 dec)	Read Multiple Registers	8	8	7	21
6h (6 dec)	Write Single Register	8	8	8	8
8h (8 dec)	Loop-Back test	8	8	8	8
10h (16 dec)	Write Multiple Registers	11	41	8	8

Read Multiple Registers – Function Code 03H

The Read Multiple Register message is used to read the contents of from one to eight consecutive registers. The formats of the read command and response messages are shown below.

► Read Multiple Registers Command Message

Description		Data
Slave Address		02h
Function Code		03h
Starting Register	Upper	00h
	Lower	20h
Quantity	Upper	00h
	Lower	04h
CRC-16	Upper	45h
	Lower	F0h

Each E7 drive slave address is set via parameter H5-01. Valid slave addresses must be in the range of 1 to 20 hex (1 to 32 dec) and entered as a hexadecimal number. No two slaves may have the same address. The master addresses the slave by placing the slave address in the Slave Address field of the message. In the command message above, the slave is addressed at 02h. Broadcast address 0 is not valid for register read commands.

The function code of this message is 03h (read multiple registers).

The starting register is the address of the first register to be read. In the command message above the starting register address is 20h (0020h).

The quantity indicates how many consecutive registers are to be read. The quantity may range from 1 to 8 registers. If an invalid quantity is entered, error code 03h is returned in a fault response message. In this example, four consecutive registers are to be read: 20h, 21h, 22h and 23h.

A CRC-16 value is generated from a calculation including the message slave address, function code, starting register and quantity. The procedure for calculating a CRC-16 is described at the end of this chapter. When the slave receives the command message it calculates a CRC-16 value and compares it to the CRC-16 of the command message. If the two CRC-16 values are identical and the Slave Address is correct, the slave processes command message. If the two CRC-16 values are not identical, the slave will discard the command message and not respond.

If the command message has a valid slave address, function code, starting register, and quantity, the slave will respond with a normal response message. If the command message has an invalid function code, starting register, and/or quantity, the slave will respond with a fault response message. If the command message has an invalid slave address or CRC-16, no response will be returned.

► Read Multiple Registers Normal Response Message

Description		Data
Slave Address		02h
Function Code		03h
Number of Data Bytes		08h
Starting Register	Upper	17h
	Lower	70h
Next Register	Upper	17h
	Lower	70h
Next Register	Upper	01h
	Lower	09h
Last Register	Upper	00h
	Lower	00h
CRC-16	Upper	38h
	Lower	ACh

The normal response message contains the same slave address and function code as the command message, indicating to the master, which slave is responding and to what type of function it is responding.

The Number Of Data Bytes is the number of data bytes returned in the response message. The number of data bytes is actually the number of registers read times 2, since there are two bytes of data in each register.

The starting register is the address of the first register read.

The data section of the response message contains the data for the registers requested read. In this case registers 20h, 21h, 22h and 23h. Their data is 20h = 1770h, 21h = 1770h, 22h = 0109h and 23h = 0h.

► Read Multiple Registers Fault Response Message

Description		Data
Slave Address		02h
Function Code		83h
Error Code		02h
CRC-16	Upper	30h
	Lower	F1h

The fault response message contains the same slave address as the command message, indicating to the master, which slave is responding.

The function code of a fault response message is the logical OR of 80h and the original function code of 03h. This indicates to the master that the message is a fault response message, instead of a normal response message.

The error code indicates where the error occurred in the command message. The value of 02h in the error code field of this fault response message indicates that the command message requested data be read from an invalid register. Refer to section Error Codes, Table 2-14, for more information on returned error codes.

Write Single Register – Function Code 06H

The Write Single Register function allows the writing of data to one register only.

► Write Single Register Command Message

Description		Data
Slave Address		01h
Function Code		06h
Register Address	Upper	00h
	Lower	01h
Data	Upper	00h
	Lower	03h
CRC-16	Upper	98h
	Lower	H0B

Each E7 drive slave address is set via parameter H5-01. Valid slave addresses must be in the range of 1 to 20 hex (1 to 32 dec) and entered as a hexadecimal number. No two slaves may have the same address. The master addresses the slave by placing the slave address in the Slave Address field of the message. In the command message above, the slave is addressed at 01h. Broadcast address 0 is valid for register write commands.

By setting the slave address to zero (0) in the command message, the master can send a message to all the slaves on the network simultaneously. This is called simultaneous broadcasting. In a simultaneous broadcast message there is no response message.

The function code of this message is 06h (write single register).

In the command message above the register address is 01h (0001h).

The data section contains the data to be that written.

A CRC-16 value is generated from a calculation including the message slave address, function code, starting register, quantity, number of data bytes and all register data. The procedure for calculating a CRC-16 is described at the end of this chapter. When the slave receives the command message it calculates a CRC-16 value and compares it to the CRC-16 of the command message. If the two CRC-16 values are identical and the slave address is correct, the slave processes command message. If the two CRC-16 values are not identical, the slave will discard the command message and not respond.

If the command message has a valid slave address, function code, register address and data, the slave will respond with a normal response message. If the command message has an invalid function code, register address and/or data, the slave will respond with a fault response message. If the command message has an invalid slave address or CRC-16, no response will be returned.

► Write Single Register Normal Response Message

Description		Data
Slave Address		01h
Function Code		06h
Register Address	Upper	00h
	Lower	01h
Data	Upper	00h
	Lower	03h
CRC-16	Upper	98h
	Lower	0Bh

The normal response message contains the same slave address, function code, register address and data as the command message, indicating to the master, which slave is responding and to what type of function it is responding.

In the response message above the register address is 01h (0001h).

► Write Single Register Fault Response Message

Description		Data
Slave Address		01h
Function Code		86h
Error Code		21h
CRC-16	Upper	82h
	Lower	78h

The fault response message contains the same slave address as the command message, indicating to the master which slave is responding.

The function code of a fault response message is the logical OR of 80h and the original function code of 06h. This indicates to the master that the message is a fault response message, instead of a normal response message.

The error code indicates where the error occurred in the command message. The value of 21h in the error code field of this fault response message indicates that the command message data to be written was invalid for that register. Refer to the section Error Codes, Table 2-14, for more information on returned error codes.

Loop-Back Test – Function Code 08H

The Loop-Back Test is used to verify that the communications parameters for the E7 drive have been set correctly and that the connection is correct. The message should be constructed exactly as shown below. If everything is set and connected correctly, the received response will match the response shown below.

► Loop-Back Test - 08h

The Loop-Back test function (08h) is used for checking signal transmission between master and slaves. The command message format is shown below.

Description		Data
Slave Address		01h
Function Code		08h
Test Code	Upper	00h
	Lower	00h
Data	Upper	A5h
	Lower	37h
CRC-16	Upper	DAh
	Lower	8Dh

Each E7 drive slave address is set via parameter H5-01. Valid slave addresses must be in the range of 1 to 20 hex (1 to 32 dec) and entered as a hexadecimal number. No two slaves may have the same address. The master addresses the slave by placing the slave address in the slave address field of the message. In the command message above, the slave is addressed at 01h. Broadcast address 0 is not valid for Loop-Back test commands.

The function code of this message is 08h (Loop-Back test).

The test code must be set to 0000h. This function specifies that the data passed in the command message is to be returned (looped back) in the response message.

The Data section contains arbitrary values.

A CRC-16 value is generated from a calculation including the message slave address, function code, test code, and data. The procedure for calculating a CRC-16 is described at the end of this chapter. When the slave receives the command message it calculates a CRC-16 value and compares it to the CRC-16 of the command message. If the two CRC-16 values are identical and the Slave Address is correct, the slave processes command message. If the two CRC-16 values are not identical, the slave will discard the command message and not respond.

If the command message has a valid slave address, function code, test code, data and CRC-16, the slave will respond with the normal response message. If the command message has an invalid function code, test code, and/or data, the slave will respond with a fault response message. If the command message has an invalid slave address or CRC-16, no response will be returned.

► Loop-Back Normal Response

The normal Loop-Back Test response is identical the command message.

Description		Data
Slave Address		01h
Function Code		08h
Test Code	Upper	00h
	Lower	00h
Data	Upper	A5h
	Lower	37h
CRC-16	Upper	DAh
	Lower	8Dh

► Loop-Back Fault Response

Description		Data
Slave Address		01h
Function Code		88h
Error Code		01h
CRC-16	Upper	87h
	Lower	C0h

The fault response message contains the same slave address as the command message, indicating to the master which slave is responding. The function code of a fault response message is the logical OR of 80h and the original function code of 08h. This indicates to the master that the message is a fault response message, instead of a normal response message.

The error code indicates where the error occurred in the command message. Refer to the section Error Codes, Table 2-14, for more information on returned error codes.

Write Multiple Registers – Function Code 10H

The Write Multiple Register function allows the writing of data to from one to sixteen consecutive registers.

► Write Multiple Registers Command Message

Description		Data
Slave Address		01h
Function Code		10h
Starting Register	Upper	00h
	Lower	01h
Quantity	Upper	00h
	Lower	02h
Number of Data Bytes		04h
First Register Data	Upper	00h
	Lower	01h
Next Register Data	Upper	02h
	Lower	58h
CRC-16	Upper	63h
	Lower	39h

Each E7 drive slave address is set via parameter H5-01. Valid slave addresses must be in the range of 1 to 20 hex (1 to 32 dec) and entered as a hexadecimal number. No two slaves may have the same address. The master addresses the slave by placing the slave address in the Slave Address field of the message. In the command message above, the slave is addressed at 01h. Broadcast address 0 is valid for register write commands.

By setting the slave address to zero (0) in the command message, the master can send a message to all the slaves on the network simultaneously. This is called simultaneous broadcasting. In a simultaneous broadcast message there is no response message.

The function code of this message is 10h (write multiple registers).

The starting register is the address of the first register to be written. In the command message above the starting register address is 01h (0001h).

The quantity indicates how many consecutive registers are to be written. The quantity may range from 1 to 16 registers. If an invalid quantity is entered, error code of 03h is returned in a fault response message. In this command message there are two consecutive registers to be written: 01h (Operation Command) and 02h (Frequency Reference).

The Number Of Data Bytes is the number of bytes of data to be written. The Number Of Data Bytes is actually the quantity multiplied by 2, since there are two bytes of data in each register.

The data section contains the data for each register to be that written in the order in which they are to be written.

A CRC-16 value is generated from a calculation including the message slave address, function code, starting register, quantity, number of data bytes and all register data. The procedure for calculating a CRC-16 is described at the end of this chapter. When the slave receives the command message it calculates a CRC-16 value and compares it to the CRC-16 of the command message. If the two CRC-16 values are identical and the slave address is correct, the slave processes command message. If the two CRC-16 values are not identical, the slave will discard the command message and not respond.

If the command message has a valid slave address, function code, starting register, quantity, number of data bytes and data, the slave will respond with a normal response message. If the command message has an invalid function code, starting register, quantity, number of data bytes and/or data, the slave will respond with a fault response message. If the command message has an invalid slave address or CRC-16, no response will be returned.

► Write Multiple Registers Normal Response Message

Description		Data
Slave Address		01h
Function Code		10h
Starting Register	Upper	00h
	Lower	01h
Quantity	Upper	00h
	Lower	02h
CRC-16	Upper	10h
	Lower	08h

The normal response message contains the same slave address, function code, starting register and quantity as the command message, indicating to the master which slave is responding and to what type of function it is responding.

The starting register is the address of the first register written. In the response message above the starting register address is 01h (0001h).

The quantity indicates how many consecutive registers were written. In this case the quantity is 2.

► Write Multiple Registers Fault Response Message

Description		Data
Slave Address		01h
Function Code		90h
Error Code		02h
CRC-16	Upper	CDh
	Lower	C1h

The fault response message contains the same slave address as the command message, indicating to the master which slave is responding.

The function code of a fault response message is the logical OR of 80h and the original function code of 10h. This indicates to the master that the message is a fault response message, instead of a normal response message.

The error code indicates where the error occurred in the command message. The value of 02h in the error code field of this fault response message indicates that the command message requested data to be written to an invalid register. Refer to the section Error Codes, Table 2-14, for more information on returned error codes.

No Response

The slave disregards the command message and does not return a response message in the following cases:

1. In simultaneous broadcasting of data (slave address field is 0), all slaves execute.
2. When a communication error (overrun, framing, parity, or CRC-16) is detected in the command message.
3. When the slave address in the command message does not coincide with the address set in the slave.
4. When it takes longer than 2 seconds to send a message.
5. When the time interval between characters exceeds 3.5ms
6. When the command message data length is not proper.

Error Codes

Code	Fault	Description
1	Function error	Invalid or unsupported function code in command message
2	Invalid Register	Invalid register address
3	Invalid Number of Registers	Invalid command message quantity
21	Data Limits Exceeded	The write command message data is out range for the requested register
22	Write Failure	The register to be written is write protected

CRC-16 Calculations

The last two bytes of a message contain the CRC-16 (Cyclical Redundancy Check). The CRC-16 is one method for verifying the validity of the message contents and is part of the protocol. The CRC-16 field checks the contents of the entire message, regardless of any parity check method used for the individual characters of the message.

The CRC-16 field is a 16-bit binary value consisting of two 8 bit bytes. The CRC-16 value is calculated by the transmitting device, which appends the CRC-16 to the message. The receiving device recalculates a CRC-16 during receipt of the message, and compares this calculated value to the value received in the transmitted CRC-16 field. If the two values are not equal, the entire message is invalid.

Detailed examples of a CRC-16 generation using Quick Basic and C are shown below.

► CRC-16 Calculation Example in Basic

```
crcsum# = &HFFFF&
crcshift# = &H0&
crcconst# = &HA001&
CLS
PRINT "*****"
PRINT
PRINT "          CRC-16 calculator"
PRINT
PRINT "*****"
PRINT "If entering data in hex, precede the data with '&H'"
PRINT "    Example: 32decimal = 20hex = &H20"
PRINT "*****"
PRINT
INPUT "Enter the number of bytes in the message: ", maxbyte
FOR bytenum = 1 TO maxbyte STEP 1
    PRINT "Enter byte ", bytenum, ":":
    INPUT byte&
    byte& = byte& AND &HFF&
    crcsum# = (crcsum# XOR byte&) AND &HFFFF&
    FOR shift = 1 TO 8 STEP 1
        crcshift# = (INT(crcsum# / 2)) AND &H7FFF&
        IF crcsum# AND &H1& THEN
            crcsum# = crcshift# XOR crcconst#
        ELSE
            crcsum# = crcshift#
        END IF
    NEXT shift
NEXT bytenum
lower& = crcsum# AND &HFF&
upper& = (INT(crcsum# / 256)) AND &HFF&

PRINT "Lower byte (1st) = ", HEX$(lower&)
PRINT "Upper byte (2nd) = ", HEX$(upper&)
```

Figure 2.1 – CRC-16 Calculation in Quick Basic

► CRC-16 Calculation Example - C

```
void    getMBCRC(char *, int, char *)           // function prototype
void    getMBCRC(char *buf, int bufLen, char *crc) { // Function name and parameter list returning a void
                                                // *buf      pointer to character array used to calculate CRC
                                                // bufLen    number of characters to calculate CRC for
                                                // *crc      pointer to the array that contains the calculated CRC

unsigned long crc_0 = 0xffff;                 // Declare and initialize variables
unsigned long crc_1 = 0x0000;                 // Declare and initialize variables
int i,j;                                       // Declare and initialize variables
    for (i=0; i<bufLen; i++) {                 // Loop through characters of input array
        crc_0 ^= ((unsigned long)buf[i] & 0x00ff); // XOR current character with 0x00ff
        for (j=0;j<8;j++) {                   // Loop through characters bits
            crc_1 = (crc_0 >> 1) & 0x7fff;     // shift result right one place and store
            if (crc_0 & 0x0001)                // if pre-shifted value bit 0 is set
                crc_0 = (crc_1 ^ 0xa001);     // XOR the shifted value with 0xa001
            else                                // if pre-shifted value bit 0 is not set
                crc_0 = crc_1;                 // set the pre-shifted value equal to the shifted value
        }                                       // End for loop - Loop through characters bits
    }                                           // End for loop - Loop through characters of input array
    crc[0] = (unsigned char)((crc_0/256) & 0x00ff); // Hi byte
    crc[1] = (unsigned char)(crc_0 & 0x00ff);   // Lo byte
return;                                       // Return to calling function
}
```

Figure 2.2 – CRC-16 Calculation in C

Chapter 3 Troubleshooting

This chapter describes some basic troubleshooting methods for serial communications

General Information	3 - 3
RS232 Communications.....	3 - 4
RS422/RS485 Communications.....	3 - 6
RS422/RS485 Self-Test	3 - 9

This page intentionally left blank.

General Information

Please fill-in the information on this and the following pages prior to contacting customer support. If customer support is necessary, please have the information below available.

- 1: E7 Drive Model _____
- 2: Input _____ VAC _____ Hz
- 3: Serial Number _____
- 4: Control Board ETC- _____
- 5: Flash ID (U1-14) _____
- 6: Initialization Type (2/3 wire control) _____
- 7: Specification Type (o2-09) _____

Please provide a sketch of the network connections in the space below.

Figure 3.1 - Connection Sketch

RS232 Communications

The following is a quick reference guide for troubleshooting RS232 serial communications to the E7 drive. Make a copy of the following pages and check-off each item as it is completed. For detailed information on the RS232 standard please refer to *EIA RS-232-C*. or later revision. For information on the E7 drive RS232 interface, refer to previous sections of this manual.

1: For RS232 communications

1.1: Verify that the correct cable is used to connect the controller to the E7 drive.

1.2: Verify that the controller is set for RS232 communications and that the communication's cable is connected to the correct communications port.

1.3: Record the controller communications' parameters

Baud Rate _____ **Parity** _____ **Data Bits** _____ **Stop Bits** _____ **Protocol** _____

1.4: Record the E7 drive communications' parameters (H5-02, H5-03, H5-07, H5-08)

Baud Rate _____ **Parity** _____ **Data Bits** _____ **Stop Bits** _____ **Protocol** _____

1.5: Verify that the communications' parameters match.

2: Check the controller RS232 wiring requirements

2.1: CTS(Clear to Send)/RTS(Ready to Send) jumper required on the controller end?

2.2: DTR(Data Terminal ready)/DSR(Data Set Ready)/RLSD(Receive Line Signal Detector) jumper required on the controller end?

2.3: TxD(Transmit Data)/RxD(Receive Data) connections are made correctly.

3: Send a message from the controller to the E7 drive.

3.1: Connect an oscilloscope between the E7 drive RxD and GND.

3.1.1: Verify that the message pulse train exists and contains the correct number of pulses. Refer to the chapter Message Formats for information on the message contents.

3.1.2: Verify that the signal levels adhere to the RS232 standard.

3.2: Insert a data analyzer in the RS232 circuit and capture the message sent by the controller in a hexadecimal format. Record the command message below.

[] [] [] [] [] [] [] [] [] []

[] [] [] [] [] [] [] [] [] []

[] [] [] [] [] [] [] [] [] []

[] [] [] [] [] [] [] [] [] []

3.3: Verify that the contents of the message adheres to the protocol format as described previously.

3.3.1: Verify that the node address is valid.

3.3.2: Verify that the function code is valid

3.3.3: Verify that the register address is valid

3.3.4: Verify that the number of data bytes is correct is valid

3.3.5: Verify that the CRC is correctly calculated.

3.3.6: Verify that the message requires a response.

4: Verify the contents of the response message.

4.1: Connect an oscilloscope between the controller RxD and GND.

4.1.1: Verify that the message pulse train exists and contains the correct number of pulses. Refer to the chapter Message Formats for information on the message contents.

4.1.2: Verify that the signal levels adhere to the RS232 standard.

4.2: Capture the response message sent by the controller in a hexadecimal format and record it below.

[]	[]	[]	[]	[]	[]	[]	[]	[]	[]
[]	[]	[]	[]	[]	[]	[]	[]	[]	[]
[]	[]	[]	[]	[]	[]	[]	[]	[]	[]
[]	[]	[]	[]	[]	[]	[]	[]	[]	[]

4.3: Verify that the contents of the message adheres to the protocol format as described previously.

4.3.1: Verify that the node address is valid.

4.3.2: Verify that the function code is valid

4.3.4: Verify that the number of data bytes is correct is valid

4.3.3: Verify that the register address is valid

4.3.4: Verify that the CRC is correctly calculated.

RS422/RS485 Communications

The following is a quick reference guide for troubleshooting RS422/RS485 serial communications to the E7 drive. Make a copy of the following pages and check-off each item as it is completed. For detailed information on the RS422/RS485 standard please refer to *EIA RS-422-A* or later revision. For information on the E7 drive RS422/RS485 interface, refer to previous sections of this manual.

1: For RS422/RS485 communications

1.1: Verify that the correct cable is used to connect the controller to the E7 drive.

1.2: Verify that the controller is set for RS422 or RS485 communications and that the communication's cable is connected to the correct communications port.

1.3: Record the controller communications' parameters

1.4: Verify that the polarity of the signal wires is correct (+ to + and - to -).

Baud Rate _____ **Parity** _____ **Data Bits** _____ **Stop Bits** _____ **Protocol** _____

1.5: Record the E7 drive communications parameters (H5-01, H5-02, H5-03, H5-07, H5-08)

Baud Rate _____ **Parity** _____ **Data Bits** _____ **Stop Bits** _____ **Protocol** _____

1.6: Verify that the communications' parameters match.

1.7: Verify that E7 drive parameter H5-07 (RTS) is set to Enable.

1.8: Verify that E7 drive parameter H5-01 (Node Address) is set to the correct, unique, hexadecimal value and that it matches the node address required by the controller.

2: Check the controller RS422/RS485 wiring requirements

2.1: The controller transmit terminals are connected to the E7 drive receive terminals and the receive terminals connected to the E7 drive transmit terminals.

2.2: The transmit and receive connection polarities are correct.

2.3: The controller either asserts RTS when transmitting or utilizes send detect circuitry.

2.4: The network is terminated only at the beginning and end of each network segment.

2.5: There are no more than 31 devices on any network segment, including the controller and repeater

3: Verify that the E7 drive passes the self-test as described in the following section.

- 4:** Send a message from the controller to the E7 drive.
 - 4.1:** Connect an oscilloscope between the E7 drive's R+ and R- terminals for RS422/RS485 4-wire networks or between terminals R+/S+ and R-/S- for RS485 2-wire networks.
 - 4.1.1:** Verify that the message pulse train exists and contains the correct number of pulses. Refer to the chapter Message Formats for information on the message contents.
 - 4.1.2:** Verify that the signal levels adhere to the RS422/RS485 standard.
 - 4.2:** Insert a data analyzer in the RS422/RS485 circuit and capture the message sent by the controller in a hexadecimal format Record the command message below.

[]
[]
[]
[]
[]
[]
[]
[]
[]
[]

[]
[]
[]
[]
[]
[]
[]
[]
[]
[]

[]
[]
[]
[]
[]
[]
[]
[]
[]
[]

[]
[]
[]
[]
[]
[]
[]
[]
[]
[]
 - 4.3:** Verify that the contents of the message adheres to the MODBUS format as described previously.
 - 4.3.1:** Verify that the node address is valid.
 - 4.3.2:** Verify that the function code is valid
 - 4.3.3:** Verify that the register address is valid
 - 4.3.4:** Verify that the number of data bytes is correct is valid
 - 4.3.5:** Verify that the CRC is correctly calculated.
 - 4.3.6:** Verify that the message requires a response.

5: Verify the contents of the response message.

5.1: Connect an oscilloscope between the controller R+ and R- terminals for RS422 and RS485 4-Wire networks or between terminals R+/S+ and R-/S- for RS485 2-wire networks.

5.1.1: Verify that the message pulse train exists and contains the correct number of pulses. Refer to the chapter Message Formats for information on the message contents.

5.1.2: Verify that the signal levels adhere to the RS422/RS485 standard.

5.2: Capture the response message in hexadecimal format and record it below.

[] [] [] [] [] [] [] [] [] []

[] [] [] [] [] [] [] [] [] []

[] [] [] [] [] [] [] [] [] []

[] [] [] [] [] [] [] [] [] []

5.3: Verify that the contents of the message adheres to the MODBUS format as described previously.

5.3.1: Verify that the node address is valid.

5.3.2: Verify that the function code is valid

5.3.3: Verify that the register address is valid

5.3.4: Verify that the number of data bytes is correct is valid

5.3.5: Verify that the CRC is correctly calculated.

RS422/RS485 Self-Test

The E7 drive can perform a self-test of the communications interface. To perform the self-test:

- Apply power to the E7 drive.
- Set parameter H1-01 to 67h (self-test).
- Remove power from the E7 drive and wait for the charge lamp to be completely extinguished. Wait at least five additional minutes for the E7 drive to be completely discharged. Measure the DC bus voltage and verify that it is at a safe level.
- Connect jumper wires to the E7 drive terminals as shown below.
- Reapply power to the E7 drive.

The frequency reference is displayed on the digital operator if the communications interface is functioning normally.

If the communications interface is not functioning, a “CE” fault is displayed on the digital operator, the E7 drive fault signal will be ON and the E7 drive ready signal will be OFF.

Termination Resistor S1

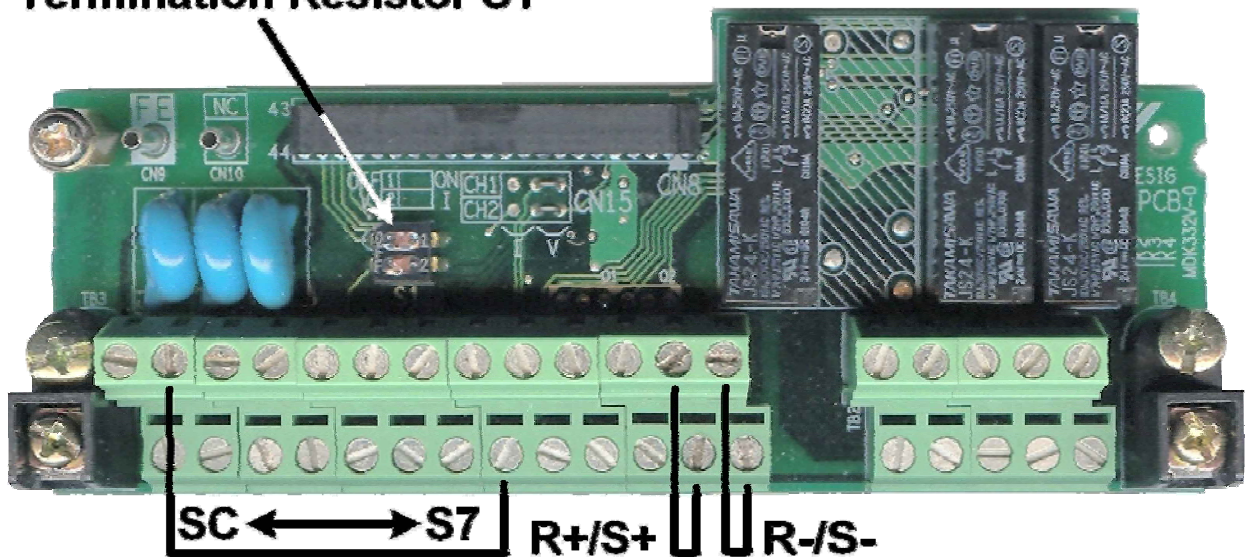

Figure 3.2 – RS422/RS485 Self-Test

This page intentionally left blank.

Chapter 4 E7 Drive Parameters

This chapter describes the E7 drive parameters, their addressing, limits and dependencies

Command Registers (Read / Write)	4 – 3
Simultaneous Broadcast Registers (Write Only)	4 – 4
Monitor Registers (Read only)	4 – 5
Parameters (Read/Write)	4 – 11
ENTER/ACCEPT Command	4 – 21
Parameter Dependencies	4 – 22

This page intentionally left blank.

Command Registers (Read / Write)

Command registers are those registers used to control the operation of the E7 drive either through a network interface (option card) or via serial communications. These registers are available during an active Run command. It should be noted that serially commanded multi-function inputs are logically OR'd with their external input terminal counterpart.

The "Addr" column contains the register address in hexadecimal format. E7 drive registers are always referred to in hexadecimal format. The "Function" column contains the register name. The "Bit" and "Description" columns contain the list of available bits for that register and a short description of each. If the "Bit" column is empty, the register contains word data and individual bits are meaningless.

Table 4.1 – Command Registers (Read / Write)			
Addr	Function	Bit	Description
0000h	Reserved		Reserved
0001h	Command	0h	0 = Stop 1 = Run
		1h	0 = Forward 1 = Reverse
		2h	External Fault
		3h	Fault reset
		4h	ComNet (0 = b1-01 = pre-selected source -- 1 = b1-01 = 3 (serial communications))
		5h	ComCtrl (0 = b1-02 = pre-selected source -- 1 = b1-02 = 3 (serial communications))
		6h	Multi-Function Input 1 @ S3 Function set by setting of H1-01
		7h	Multi-Function Input 2 @ S4 Function set by setting of H1-02
		8h	Multi-Function Input 3 @ S5 Function set by setting of H1-03
		9h	Multi-Function Input 4 @ S6 Function set by setting of H1-04
		Ah	Multi-Function Input 5 @ S7 Function set by setting of H1-05
		Bh	Reserved
		Ch	Reserved
		Dh	Reserved
Eh	Reserved		
Fh	Reserved		
0002h	Frequency Reference		Dependent on setting of o3-02
0003h	Reserved		Reserved
0004h	Reserved		Reserved
0005h	Reserved		Reserved
0006h	PID Setpoint		
0007h	Analog Output 1 Setting		(-11 ~ 11)/726 Vdc
0008h	Analog Output 2 Setting		(-11 ~ 11)/726 Vdc
0009h	Outputs	0h	Multi-Function Output 1
		1h	Multi-Function Output 2
		2h	Multi-Function Output 3
		3h	Reserved
		4h	Reserved
		5h	Reserved
		6h	Fault Relay Output
		7h	Fault Relay N.C.
		8h-Fh	Reserved
000Ah	Reserved		Reserved
000Bh	Reserved		Reserved
000Ch	Reserved		Reserved
000Dh	Reserved		Reserved
000Eh	Reserved		Reserved
000Fh	Command Selection	0h	Reserved
		1h	PID Value 0006h is used
		2h-Bh	Reserved
		Ch	Simultaneous Broadcast Data Terminal S5 Enable*
		Dh	Simultaneous Broadcast Data Terminal S6 Enable*
		Eh	Simultaneous Broadcast Data Terminal S7 Enable*
		Fh	Reserved

Note: * These bits must be set in order to use the Simultaneous Broadcast Register multi-function inputs 3, 4, 5 and 6 (bits 0Ch, 0Dh, 0Eh and 0Fh respectively). Refer to *Table 4.2 - Simultaneous Broadcast Registers (Write only)*.

Simultaneous Broadcast Registers (Write only)

Simultaneous Broadcast Registers are those registers used to control the simultaneous operation of multiple devices either through a network interface (option card) or via serial communications. These registers are available during drive RUN.

The “Addr” column contains the register address in hexadecimal format. Drive registers are always referenced in hexadecimal format. The “Function” column contains the register name. The “Bit” and “Description” columns contain the list of available bits for that register and a short description of each. If the “Bit” column is empty, the register contains word data and individual bits are meaningless.

Addr	Function	Bit	Description
0000h	Reserved		Reserved
0001h	Command	0h	0 = Stop 1 = Run
		1h	0 = Forward 1 = Reverse
		2h	
		3h	
		4h	
		5h	Multi-Function Input 1 @ S3 (default = External Fault) Function set by setting of H1-01
		6h	Multi-Function Input 2 @ S4 (default = Fault Reset) Function set by setting of H1-02
		7h	
		8h	
		9h	
		Ah	
		Bh	
Ch	Multi-Function Input 3 @ S5* Function set by setting of H1-03		
Dh	Multi-Function Input 4 @ S6* Function set by setting of H1-04		
Eh	Multi-Function Input 5 @ S7* Function set by setting of H1-05		
Fh	Reserved		
0002h	Frequency Reference		30000/100%**

Note: * Use of these bits is dependent on the setting of register 0Fh bits 0Ch, 0Dh and 0Eh. Refer to **Table 4.1 – Command Registers (Read / Write)**.
 ** This value must be sent to the drive as a hexadecimal value. Example: 4096 = 1000h.
 The scaling is fixed at 30000/100%, and is not affected by parameter o1-03.
 It is affected by the maximum frequency of the drive receiving the command. Simply it is ((decimal freq ref)/30000)* (drive’s maximum frequency).
 Example: Send 1000h to drive. 1000h = 4096 decimal.
 (4096*100%)/30000 = 13.65%.
 If drive’s maximum frequency is 60Hz, then the frequency reference command to the drive is 60*13.65% or 8.19Hz.

Monitor Registers (Read only)

The following table lists monitor parameters for the E7 drive. These parameters are used to monitor E7 drive information and cannot be written.

- The “U-##” column contains the reference, if it exists, to the “U”, monitor, parameter displayed via the operator keypad.
- The “Addr” column contains the register addresses for that parameter in hexadecimal format. E7 drive registers are always referred to in hexadecimal format.
- The “Function” column contains the register name.
- The “Bit” column contains the list of available bits for that register. If the “Bit” column is empty, the register contains word data and the individual bits are meaningless.
- The “Description” column contains a short description of each register or register bit.
- Reserved registers and data are meaningless and should be ignored

Table 4.3 - Monitor Registers (Read only)

U-##	Addr	Function	Bit	Description
	0010h	Inverter Status	0h	@ RUN
			1h	Reserved
			2h	Reserved
			3h	@ Reset Signal
			4h	@ Speed Agree
			5h	@ Inverter Ready
			6h	@ Minor Fault
			7h	@ Major Fault
			8h-Dh	Reserved
			Eh	@ ComRef
			Fh	@ ComCtrl
	0011h	Operator Status	0	@ OPE
			1	@ ERR
			2	@ PRG Mode
			3	0: Operator 1: PC
			4h-Fh	Reserved
	0012h	OPE	0h	Reserved
			1h	OPE1 @ E7 drive kVA Setting Error
			2h	OPE2 @ Parameter Setting Out of Range
			3h	OPE3 @ Multi-Function Input Selection
			4h	Reserved
			5h	OPE5 @ Run Command Selection Error - Option board missing
			6h	OPE6 @ Control Method Selection Error - PG Opt Missing
			7h	OPE7 @ Multi-Function Analog Input Select Error
			8h	OPE8 @ Function Selection Error for current control mode
			9h	OPE9 @ PID Control Setup Error
			Ah	OPE10 @ V/F Parameter/Pattern Setting Error
			Bh	OPE11 @ Carrier Frequency Parameter Setting Error
			Ch	Reserved
			Dh	Reserved
			Eh	Reserved
Fh	Reserved			
	0013h	Inverter Product Code	0000h	G5
			1000	V7
			2010	E7
			2020	E7C (YEC)
			2030	E7A (YEG)
			2040	E7U (YEA)
			2050	G7C (YEC)
			2060	G7A (YEG)
			2070	G7U (YEA)
			2080	VG7
2130	P7			

Table 4.3 - Monitor Registers (Read only)

U-##	Addr	Function	Bit	Description
0014h	Fault Contents 1	0h	(PUF) @ Fuse	
		1h	(UV1) @ Main Circuit Undervoltage	
		2h	(UV2) @ Control Circuit Undervoltage	
		3h	(UV3) @ MC Error	
		4h	Reserved	
		5h	(GF) @ Ground Fault	
		6h	(OC) @ Over Current	
		7h	(OV) @ Overvoltage	
		8h	(OH) @ Inverter Overheat	
		9h	(OH1) @ Inverter Overheat Warning	
		Ah	(OL1) @ Motor Overload	
		Bh	(OL2) @ Inverter Overload	
		Ch	(OL3) @ Overtorque 1	
		Dh	(OL4) @ Overtorque 2	
		Eh	(RR) @ Braking Resistor Fault	
		Fh	(RH) @ Braking resistor Overheat	
0015h	Fault Contents 2	0h	(EF3) @ External Fault 3	
		1h	(EF4) @ External Fault 4	
		2h	(EF5) @ External Fault 5	
		3h	(EF6) @ External Fault 6	
		4h	(EF7) @ External Fault 7	
		5h	Reserved	
		6h	Reserved	
		7h	(OS) @ Overspeed	
		8h	(DEV) @ Excessive Speed Bias	
		9h	(PGO) @ PG Line Interruption	
		Ah	(PF) @ Input Phase Fault	
		Bh	(LF) @ Output Phase Fault	
		Ch	(OH3) @ Overheat	
		Dh	(OPR) @ Operator Bypass Fault	
		Eh	(ERR) @ EEPROM Write Fault	
		Fh	(OH4) @ Motor Overheat Fault	
0016h	Fault Contents 3	0h	(CE) @ Communications Fault	
		1h	(BUS) @ Communications Option Fault	
		2h	(E-15) @ SI-F/G Communication Fault	
		3h	(E-10) @ SI-F/G Fault	
		4h	(CF) @ Control Fault	
		5h	(SVE) @ Zero Servo Fault	
		6h	(EF0) @ Communications Option External Fault	
		7h	(FBL) @ PID Feedback Error	
		8h	(UL3) @ Undertorque 1	
		9h	(UL4) @ Undertorque 2	
		Ah	(OL7) @ High Slip braking Overload	
		Bh	Reserved	
		Ch	Reserved	
		Dh	Reserved	
		Eh	Reserved	
		Fh	Reserved	
0017h	CPF Contents 1	0h	Reserved	
		1h	Reserved	
		2h	CPF02 @ Base Block Circuit Error	
		3h	CPF03 @ EEPROM Error	
		4h	CPF04 @ CPU Internal A/D Converter Error	
		5h	CPF05 @ CPU External A/D Converter Error	
		6h	CPF06 @ Option Card Connection Error	
		7h-Fh	Reserved	
0018h	CPF Contents 2	0h	CPF20 @ Option Card A/D Converter Error	
		1h	CPF21 @ Option Card Self-Diagnostic error	
		2h	CPF22 @ Option Card Option Code Error	
		3h	CPF23 @ Option Card DP-RAM Error	
		4h-Fh	Reserved	

Table 4.3 - Monitor Registers (Read only)

U-##	Addr	Function	Bit	Description
0019h	Minor Fault Contents 1	0h	(UV) @ Undervoltage	
		1h	(OV) @ Overvoltage	
		2h	(OH) @ Inverter Overheat	
		3h	(OH2) @ Inverter Overheat Warning	
		4h	(OL3) @ Overtorque 1	
		5h	(OL4) @ Overtorque 2	
		6h	(EF) @ 2-wire Sequence Input Fault	
		7h	(BB) @ Baseblock	
		8h	(EF3) @ External Fault 3	
		9h	(EF4) @ External Fault 4	
		Ah	(EF5) @ External Fault 5	
		Bh	(EF6) @ External Fault 6	
		Ch	(EE7) @ External Fault 7	
		Dh	Reserved	
		Eh	Reserved	
		Fh	(OS) @ Overspeed	
001Ah	Minor Fault Contents 2	0h	(DEV) @ Excessive Speed Bias	
		1h	(PGO) @ PG Line Interruption	
		2h	(OPR) @ Operator Bypass Fault	
		3h	(CE) @ Communications Fault	
		4h	(BUS) @ Communications Option Fault	
		5h	(CALL) @ Waiting for Communications	
		6h	(OL1) @ Motor Overload	
		7h	(OL2) @ Inverter Overload	
		8h	(E-15) @ SI-F/G Communication Fault	
		9h	(E-10) @ SI-F/G Fault	
		Ah	@ Motor Switch	
		Bh	(FBL) @ PID Feedback Error	
		Ch	(CALL) @ Waiting for Communications	
		Dh	(UL3) @ Undertorque 1	
		Eh	(UL4) @ Undertorque 2	
		Fh	@ Communication Test Fault	
001Bh	Minor Fault Contents 3	0h	(OH3) @ Motor Overheat Alarm	
		1h	(DNE) @ E7 drive Not Enabled	
		2h	Reserved	
		3h	Reserved	
		4h	Reserved	
		5h-Fh	Reserved	
001Ch	Reserved		Reserved	
001Dh	Reserved		Reserved	
001Eh	Reserved		Reserved	
001Fh	Reserved		Reserved	
0020h	Inverter Status	0h	@ RUN	
		1h	@ Reverse	
		2h	@ Inverter Ready	
		3h	@ Fault	
		4h	@ Data Setting Error	
		5h	Multi-Function Output 1	
		6h	Multi-Function Output 2	
		7h	Multi-Function Output 3	
		8h	Reserved	
		9h	Reserved	
		Ah-Fh	Reserved	
0021h	Fault Contents	0h	(OC) or (GF) @ Overcurrent/Ground Fault	
		1h	(OV) @ Overvoltage	
		2h	(OL2) @ Inverter Overload	
		3h	(OH1) or (OH2) @ Overheat Fault	
		4h	(RR) or (RH) @ Braking Resistor Fault	
		5h	(PUF) @ Fuse Fault	
		6h	(FBL) @ PID Feedback Fault	
		7h	(EF#) @ External Fault	
		8h	(CPF) @ Hardware Fault	
		9h	(OL1) or (OL3) or (OL4) @ Overload/Overtorque	
		Ah	(PGO) or (OS) or (DEV) @ Excessive Speed Deviation	
		Bh	(UV) @ Undervoltage	
		Ch	(UV1) or (UV2) or (UV3) or Power Off	
		Dh	(SPI) or (SPO) @ Input/Output Phase Fault	
		Eh	(CE) @ Communications Error	
		Fh	(OPR) @ Operator Error	
0022h	Data Link Status	0	@ Data Writing	
		1	Reserved	
		2	Reserved	
		3	@ Data Limit Fault	
		4	@ Data Compatibility fault	
		5h-Fh	Reserved	
0023h	Frequency Reference		See U1-01	

Table 4.3 - Monitor Registers (Read only)

U-##	Addr	Function	Bit	Description
	0024h	Output Frequency		See U1-02
	0025h	Reserved		Reserved
	0026h	Reserved		Reserved
	0027h	Output Power		See U1-08
	0028h	Torque Command		See U1-09
	0029h	Reserved		Reserved
	002Ah	Reserved		Reserved
	002Bh	Sequence Input Status	0h	Terminal 1 Closed
			1h	Terminal 2 Closed
			2h	Terminal 3 Closed
			3h	Terminal 4 Closed
			4h	Terminal 5 Closed
			5h	Terminal 6 Closed
			6h	Terminal 7 Closed
			7h	Reserved
			8h	Reserved
			9h	Reserved
			Ah	Reserved
			Bh	Reserved
			Ch-Fh	Reserved
	002Ch	Inverter Status	0h	@ RUN
			1h	@ Zero Speed
			2h	@ Speed Agree
			3h	@ Random Speed Agree
			4h	@ Frequency Detect 1
			5h	@ Frequency Detect 2
			6h	@ Inverter Ready
			7h	@ Undervoltage
			8h	@ Baseblock
			9h	@ Frequency Reference Not From Communications
			Ah	@ Command Reference Not From Communications
			Bh	@ Overtorque
			Ch	@ Loss of Frequency reference
			Dh	@ Fault Retry
			Eh	@ Fault
	Fh	@ Communications Timeout		
	002Dh	Multi-Function Output Status	0h	Multi-Function Output 1
			1h	Multi-Function Output 2
			2h	Multi-Function Output 3
			3h	Reserved
			4h	Reserved
			5h-Fh	Reserved
	002Eh	Reserved		Reserved
	002Fh	Reserved		Reserved
	0030h	Reserved		Reserved
	0031h	Main Circuit DC Voltage		
	0032h	Torque		
	0033h	Output Power		See U1-08
	0034h	Reserved		Reserved
	0035h	Reserved		Reserved
	0036h	Reserved		Reserved
	0037h	Reserved		Reserved
	0038h	PID Feedback Level		
	0039h	PID Input Level		
	003Ah	PID Output Level		
	003Bh	CPU		CPU Revision
	003Ch	Flash ID		Software Revision
	003Dh	Communications Error	0h	@ CRC Error
			1h	@ Data Length Error
			2h	Reserved
			3h	@ Parity Error
			4h	@ Overrun Error
			5h	@ Framing Error
			6h	@ Timeout
	7h-Fh	Reserved		
	003Eh	kVA Setting		See Parameter o2-04
	003Fh	Reserved		Reserved
U1-01	0040h	Frequency Reference		Units 0.01Hz
U1-02	0041h	Output Frequency		Units 0.01Hz
U1-03	0042h	Output Current		Units 0.1A
U1-06	0045h	Output Voltage		Units 0.1Vac
U1-07	0046h	DC Bus Voltage		Units 1.0Vdc
U1-08	0047h	Output Power		Units 0.1kW

Table 4.3 - Monitor Registers (Read only)

U-##	Addr	Function	Bit	Description
U1-10	0049h	Input Terminal Status	0h	Fwd Run (Terminal S1)
			1h	Rev Run (Terminal S2)
			2h	Terminal S3
			3h	Terminal S4
			4h	Terminal S5
			5h	Terminal S6
			6h	Terminal S7
			7h	Reserved
			8h	Reserved
			9h	Reserved
			Ah	Reserved
			Bh	Reserved
			Ch-Fh	Reserved
U1-11	004Ah	Output Terminal Status	0h	Multi-function Output 1
			1h	Multi-function Output 2
			2h	Multi-function Output 3
			3h	Reserved
			4h	Reserved
			5h	Reserved
			6h	Reserved
			7h	Fault Output
			8h - Fh	Reserved
U1-12	004Bh	E7 drive Operation Status	0h	@ FWD RUN
			1h	@ Zero Speed
			2h	@ REV RUN
			3h	@ Reset
			4h	@ Speed Agree
			5h	@ E7 drive Ready
			6h	@ Minor Fault
			7h	@ Major Fault
			8h - Fh	Reserved
U1-13	004Ch	Elapsed Time		Units 1.0hr
U1-14	004Dh	Flash ID		Software Revision
U1-15	004Eh	Terminal A1 Input Voltage		Units 0.1%
U1-16	04Fh	Terminal A2 Input Voltage		Units 0.1%
U1-18	0051h	Motor Secondary Current (Iq)		Units 0.1%
U1-20	0053h	Output Frequency After Soft Start		Units 0.01Hz
U1-24	0057h	PID Feedback Value		Units 0.01%
U1-28	005Bh	CPU Number		CPU Revision
U1-29	005Ch	kWh		Units 1.0kWh
U1-30	005Dh	MWh		Units 1.0MWh
U1-34	0061h	First Parameter Causing an OPE Fault		
U1-36	0063h	PID Input		Units 0.1%
U1-37	0064h	PID Output		Units 0.1%
U1-38	0065h	PID Setpoint		Units 0.1%
U1-39	0066h	Communication Error Code	0	CRC Error
			1	Data Length Error
			2	Reserved
			3	Parity Error
			4	Over-run Error
			5	Framing Error
			6	Timeout Error
			7h - Fh	Reserved
U1-40	0067h	FAN Elapsed Time		Units 1H
U1-41	0068h	Actual Fin Temp		Units Deg C
U1-51	0072h	AUTO Mode Fref		Units 0.1%
U1-52	0073h	HAND Mode Fref		Units 0.1%
U1-53	0074h	PI Feedback 2		Units 0.1%
U2-01	0080h	Current Fault		
U2-02	0081h	Previous Fault		
U2-03	0082h	Frequency Reference @ Previous Fault		Units 0.01Hz
U2-04	0083h	Output Frequency @ Previous Fault		Units 0.01Hz
U2-05	0084h	Output Current @ Previous Fault		Units 0.1A
U2-07	0086h	Output Voltage @ Previous Fault		Units 0.1V
U2-08	0087h	DC Bus Voltage @ Previous Fault		Units 1.0Vdc
U2-09	0088h	Output Power @ Previous Fault		Units 0.1kW
U2-10	0089h	Torque Reference @ Previous Fault		Units 0.1%
U2-11	008Ah	Input Terminal Status @ Previous Fault		(See U1-10 Description)
U2-12	008Bh	Output Terminal Status @ Previous Fault		(See U1-11 Description)
U2-13	008Ch	E7 drive Operation Status @ Previous Fault		(See U1-12 Description)
U2-14	008Dh	Elapsed Time @ Previous Fault		Units 1.0hr

Table 4.3 - Monitor Registers (Read only)

U-##	Addr	Function	Bit	Description	
U3-01	0800h	Most Recent Fault		Also @ 0090H	See o2-09
U3-02	0801h	2nd Most Recent Fault		Also @ 0091H	See o2-09
U3-03	0802h	3rd Most Recent Fault		Also @ 0092H	See o2-09
U3-04	0803h	4th Most Recent Fault		Also @ 0093H	See o2-09
U3-05	080Ah	Elapsed Time @ Most Recent Fault		Units 1.0hr Also @ 0094H	See o2-09
U3-06	080Bh	Elapsed Time @ 2nd Most Recent Fault		Units 1.0hr Also @ 0095H	See o2-09
U3-07	080Ch	Elapsed Time @ 3rd Most Recent Fault		Units 1.0hr Also @ 0096H	See o2-09
U3-08	080Dh	Elapsed Time @ 4th Most Recent Fault		Units 1.0hr Also @ 0097H	See o2-09
U3-09	0804h	5th Most Recent Fault			See o2-09
U3-10	0805h	6th Most Recent Fault			See o2-09
U3-11	0806h	7th Most Recent Fault			See o2-09
U3-12	0807h	8th Most Recent Fault			See o2-09
U3-13	0808h	9th Most Recent Fault			See o2-09
U3-14	0809h	10th Most Recent Fault			See o2-09
U3-15	080Eh	Elapsed Time @ 5th Most Recent Fault		Units 1.0hr	See o2-09
U3-16	080Fh	Elapsed Time @ 6th Most Recent Fault		Units 1.0hr	See o2-09
U3-17	0810h	Elapsed Time @ 7th Most Recent Fault		Units 1.0hr	See o2-09
U3-18	0811h	Elapsed Time @ 8th Most Recent Fault		Units 1.0hr	See o2-09
U3-19	0812h	Elapsed Time @ 9th Most Recent Fault		Units 1.0hr	See o2-09
U3-20	0813h	Elapsed Time @ 10th Most Recent Fault		Units 1.0hr	See o2-09

Parameters (Read/Write)

The following table lists user accessible parameters for the F7 drive.

- The “Prm” column contains the parameter name.
- The “Addr” column contains the register address in hexadecimal format. F7 drive registers are always referred in hexadecimal format.
- The “Data” column contains the available selections for those parameters whose value is selected from a list. If the Data column is empty, that parameter’s value is entered as a number within the limits shown in the “± Limits / Selection”
- The “+/- Limits / Selection” column contains:
 - The name of the selection if the Data column is not empty
 - The upper and lower limits of the data that can be entered for that parameter
- The “Inc” column describes the smallest increment with which the parameter value may be changed. Since all parameter values are sent and received as whole numbers, the “Inc” value also describes how that value should be scaled.
- The “RUN” column describes whether the parameter is able to be written while the RUN command is active.
 - “Y” - the parameter is writable during RUN
- The “Acs” columns describe the accessibility
 - “A” - the parameter requires Advanced access (A1-01 = 2)
 - “O” - the parameter has Operation access (A1-01 = 0)
 - “F” – the parameter requires factory access
 - “N” – the parameter is not accessible
- The “Dep” column shows whether the value, definition or function of the selected parameter is dependent on the setting of another parameter. If there is an “*” in the “Dep” column, refer to the appropriate table at the end of this section.

Notes:

- Factory parameters are shown shaded and are included here for information purposes only
- Parameter defaults are listed for the F7U drive.
- All parameters are sent and received as whole numbers regardless of how they are represented in the “+/- Limits / Selection” column or their increment. For example, parameter b4-01, Delay-ON Timer, has limits of 0.0 ~ 3000.0 seconds with an increment of 0.1 seconds. If parameter b4-01 is read and a value of 600 returned, the actual value is 60.0 seconds. If parameter b4-01 is to be set to 30 seconds, a value of 300 (30.0 seconds) must be sent.

Prm	Adr	Function	Data	Limits / Selections	Inc	Default	Run	Acs	Dep
A1-00	0100h	Select Language	0	English	1	0	Run	O	
			1	Japanese					
			2	Deutsch					
			3	Français					
			4	Italiano					
			5	Español					
A1-01	0101h	Access Level	0	Operation Only	1	2	Run	A	
			2	Advanced Level					
			616	Factory Level					
A1-03	0103h	Init Parameters	0	No Initialize	1	0		A	
			2220	2-Wire Initial					
			3330	3-Wire Initial					
A1-04	0104h	Enter Password	0 ~ 9999		1	0		O	
A2-01	0106h	User Param 1	0h ~ 5ffh		1	0h		A	
A2-02	0107h	User Param 2	0h ~ 5ffh		1	0h		A	
A2-03	0108h	User Param 3	0h ~ 5ffh		1	0h		A	
A2-04	0109h	User Param 4	0h ~ 5ffh		1	0h		A	
A2-05	010Ah	User Param 5	0h ~ 5ffh		1	0h		A	
A2-06	010Bh	User Param 6	0h ~ 5ffh		1	0h		A	
A2-07	010Ch	User Param 7	0h ~ 5ffh		1	0h		A	
A2-08	010Dh	User Param 8	0h ~ 5ffh		1	0h		A	
A2-09	010Eh	User Param 9	0h ~ 5ffh		1	0h		A	
A2-10	010Fh	User Param 10	0h ~ 5ffh		1	0h		A	
A2-11	0110h	User Param 11	0h ~ 5ffh		1	0h		A	
A2-12	0111h	User Param 12	0h ~ 5ffh		1	0h		A	
A2-13	0112h	User Param 13	0h ~ 5ffh		1	0h		A	
A2-14	0113h	User Param 14	0h ~ 5ffh		1	0h		A	
A2-15	0114h	User Param 15	0h ~ 5ffh		1	0h		A	
A2-16	0115h	User Param 16	0h ~ 5ffh		1	0h		A	
A2-17	0116h	User Param 17	0h ~ 5ffh		1	0h		A	
A2-18	0117h	User Param 18	0h ~ 5ffh		1	0h		A	
A2-19	0118h	User Param 19	0h ~ 5ffh		1	0h		A	
A2-20	0119h	User Param 20	0h ~ 5ffh		1	0h		A	
A2-21	011Ah	User Param 21	0h ~ 5ffh		1	0h		A	
A2-22	011Bh	User Param 22	0h ~ 5ffh		1	0h		A	
A2-23	011Ch	User Param 23	0h ~ 5ffh		1	0h		A	

Addresses for parameters b1-01 ~ 03-01

Prm	Adr	Function	Data	Limits / Selections	Inc	Default	Run	Acs	Dep
A2-24	011Dh	User Param 24		0h ~ 5ffh	Addresses for parameters b1-01 ~ 03-01	1	0h		A
A2-25	011Eh	User Param 25		0h ~ 5ffh		1	0h		A
A2-26	011Fh	User Param 26		0h ~ 5ffh		1	0h		A
A2-27	0120h	User Param 27		0h ~ 5ffh		1	0h		A
A2-28	0121h	User Param 28		0h ~ 5ffh		1	0h		A
A2-29	0122h	User Param 29		0h ~ 5ffh		1	0h		A
A2-30	0123h	User Param 30		0h ~ 5ffh		1	0h		A
A2-31	0124h	User Param 31		0h ~ 5ffh		1	0h		A
A2-32	0125h	User Param 32		0h ~ 5ffh		1	0h		A
b1-01	0180h	Reference Source	0	Operator		1	1		A
			1	Terminals					
			2	Serial Com					
			3	Option PCB					
b1-02	0181h	Run Source	0	Operator	1	1		A	
			1	Terminals					
			2	Serial Com					
			3	Option PCB					
b1-03	0182h	Stopping Method	0	Ramp to Stop	1	0		A	
			1	Coast to Stop					
			2	DCInj to Stop					
			3	Coast w/Timer (C1-09)					
b1-04	0183h	Reverse Oper	0	Reverse Enabled	1	1		A	o2-09*
			1	Reverse Disabled					
			2	Exchange Phase					
			3	ExchgPhs,RevDsbl					
b1-07	0186h	LOC/REM RUN Sel	0	Cycle Extrn RUN	1	0		A	
			1	Accept Extrn RUN					
b1-08	0187h	RUN CMD at PRG	0	Disabled	1	0		A	
			1	Enabled					
b1-09	0188h	L/R Select@Drive	0	Disabled	1	0		F	
			1	Enabled					
b1-11	01DFh	Wait to Run Time		0 ~ 600 Sec	1 Sec	0 Sec		A	
b1-12	01E0h	HAND Pref Source	0	Operator	1	0		A	
			1	Terminals					
b2-01	0189h	DCInj Start Freq		0.0 ~ 10.0 Hz	0.1 Hz	0.5 Hz		A	
b2-02	018Ah	DCInj Current		0 ~ 100 %	1%	50%		A	
b2-03	018Bh	DCInj Time@Start		0.0 ~ 10.0 Sec	0.01 Sec	0.0 Sec		A	
b2-04	018Ch	DCInj Time@Stop		0.0 ~ 10.0 Sec	0.01 Sec	0.0 Sec		A	o2-09*
b2-05	018Dh	DCInj P Gain		0.0 ~ 1.0	0.01	0.05		F	
b2-06	018Eh	DCInj Intgl Time		0 ~ 1000 ms	1 ms	100 ms		F	
b2-07	018Fh	DCInj Limit		0.0 ~ 30.0 %	0.10%	15.00%		F	
b2-09	01E1h	Preheat Current		0 ~ 100 %	1%	0%		A	
b3-01	0191h	SpdSrch at Start	0	SpdsrchF Disable	1	0		A	
			1	SpdsrchF Enable					
			2	SpdsrchI Disable					
			3	SpdsrchI Enable					
b3-02	0192h	SpdSrch Current		0 ~ 200 %	1%	120%		A	
b3-03	0193h	SpdSrch Dec Time		0.1 ~ 10.0 Sec	0.1 Sec	2.0 Sec		A	kVA*
b3-04	0194h	SpdSrch V/F		10 ~ 100 %	1%	100%		F	kVA*
b3-05	0195h	Search Delay		0.0 ~ 20.0 Sec	0.1 Sec	0.2 Sec		A	
b3-06	0196h	Srch Im Lvl1		0.0 ~ 1.0	0.1	0.5		F	kVA*
b3-07	0197h	Srch Im Lvl2		0.0 ~ 3.0	0.1	1		F	
b3-08	0198h	Srch ACR P Gain		0.0 ~ 6.0	0.01	0.5		F	kVA*
b3-09	0199h	Srch ACR I Time		0.0 ~ 1000.0 ms	0.1 ms	2.0 ms		F	
b3-10	019Ah	Srch Detect Comp		1.0 ~ 1.5	0.01	1.1		F	
b3-11	019Bh	Srch Mthd Sw Lvl		0.5 ~ 100.0 %	0.10%	5.00%		F	
b3-12	019Ch	Srch I Deadband		2.0 ~ 5.0	0.1	2.5		F	
b3-14	019Eh	Bidir Search Sel	0	Disabled	1	1		A	
			1	Enabled					
b4-01	01A3h	Delay-ON Timer		0.0 ~ 3000.0 Sec	0.1 Sec	0.0 Sec		A	
b4-02	01A4h	Delay-OFF Timer		0.0 ~ 3000.0 Sec	0.1 Sec	0.0 Sec		A	
b5-01	01A5h	PI Mode	0	Disabled	1	0		A	
			1	Enabled					
			2	Enabled					
			3	Fref+PI					
			4	Fref+PI					
b5-02	01A6h	P Gain		0.0 ~ 25.0	0.01	2	Run	A	o2-09*
b5-03	01A7h	PI I Time		0.0 ~ 360.0 Sec	0.1 Sec	5.0 Sec	Run	A	o2-09*
b5-04	01A8h	PI I Limit		0.0 ~ 100.0 %	0.10%	100.00%	Run	A	
b5-06	01AAh	PI Limit		0.0 ~ 100.0 %	0.10%	100.00%	Run	A	
b5-07	01ABh	PI Offset		-100.0 ~ 100.0 %	0.10%	0.00%	Run	A	
b5-08	01ACh	PI Delay Time		0.0 ~ 10.0 Sec	0.01 Sec	0.0 Sec	Run	A	
b5-09	01ADh	Output Level Sel	0	Normal Output	1	0		A	
			1	Reverse Output					
b5-10	01AEh	Output Gain		0.0 ~ 25.0	0.1	1		A	

Prm	Adr	Function	Data	Limits / Selections	Inc	Default	Run	Acs	Dep
b5-11	01AFh	Output Rev Sel	0	0 limit	1	0		A	
			1	Reverse					
b5-12	01B0h	Fb los Det Sel	0	Disabled	1	0		A	
			1	Alarm					
			2	Fault					
b5-13	01B1h	Fb los Det Lvl		0 ~ 100 %		1%	0%		A
b5-14	01B2h	Fb los Det Time		0.0 ~ 25.5 Sec	0.1 Sec	1.0 Sec			A
b5-15	01B3h	Sleep Level		0.0 ~ 200.0 Hz	0.1 Hz	0.0 Hz			A
b5-16	01B4h	Sleep Time		0.0 ~ 25.5 Sec	0.1 Sec	0.0 Sec			A
b5-17	01B5h	Acc/Dec Time		0.0 ~ 25.5 Sec	0.1 Sec	0.0 Sec			A
b5-18	01DCh	PI Setpoint Sel	0	Disabled	1	0		A	
			1	Enabled					
b5-19	01DDh	PI Setpoint		0.0 ~ 100.0 %	0.10%	0.00%	Run		A
b5-20	01E2h	Setpoint Scaling		0 ~ 39999	1	1			A
b5-21	01E3h	PI Sleep Source	0	SFS Input	1	1		A	
			1	PI Setpoint					
			2	Snooze					
b5-22	01E4h	Snooze Level		0 ~ 100 %	1%	0%	Run		A
b5-23	01E5h	Snooze DelayTime		0 ~ 3600 Sec	1 Sec	0 Sec			A
b5-24	01E6h	Wake-Up Level		0 ~ 100 %	1%	0%			A
b5-25	01E7h	Setpoint Boost		0 ~ 100 %	1%	0%			A
b5-26	01E8h	Max Boost Time		0 ~ 3600 Sec	1 Sec	0 Sec			A
b5-27	01E9h	Snooze Feedback		0 ~ 100 %	1%	60%			A
b5-28	01EAh	PI Feedback SqRt	0	Disabled	1	0		A	
			1	Enabled					
b5-29	01EBh	PI Fb SqRt Gain		0.0 ~ 2.0	0.01	0			A
b5-30	01ECh	PI Out Moni SqRt	0	Disabled	1	0		A	
			1	Enabled					
b8-01	01CCh	Energy Save Sel	0	Disabled	1	0		A	
			1	Enabled					
b8-04	01CFh	Energy Save COEF		0.0 ~ 655.0	0.01	288.2		A	kVA*
b8-05	01D0h	kW Filter Time		0 ~ 2000 ms	1 ms	20 ms			A
b8-06	01D1h	Search V Limit		0 ~ 100 %	1%	0%			A
b8-07	01D2h	E-Sav V Low Lim1		0 ~ 100 %	1%	50%		F	
b8-08	01D3h	E-Sav V Low Lim2		0 ~ 25 %	1%	12%		F	
b8-09	01D4h	E-Sav V Up Lim1		0 ~ 120 %	1%	120%		F	
b8-10	01D5h	E-Sav V Up Lim2		0 ~ 25 %	1%	16%		F	
b8-11	01D6h	Srch V Step 100%		0.1 ~ 10.0 %	0.10%	0.50%		F	
b8-12	01D7h	Srch V Step 5%		0.1 ~ 10.0 %	0.10%	0.20%		F	
b8-13	01D8h	Srch V Avg Time		1 ~ 5000 ms	1 ms	25 ms		F	
b8-14	01D9h	Srch kW Hold Wth		0 ~ 100 %	1%	10%		F	
C1-01	0200h	Accel Time 1		0.0 ~ 6000.0 Sec	0.1 Sec	30.0 Sec	Run	A	o2-09*
C1-02	0201h	Decel Time 1		0.0 ~ 6000.0 Sec	0.1 Sec	30.0 Sec	Run	A	o2-09*
C1-03	0202h	Accel Time 2		0.0 ~ 6000.0 Sec	0.1 Sec	30.0 Sec	Run	A	o2-09*
C1-04	0203h	Decel Time 2		0.0 ~ 6000.0 Sec	0.1 Sec	30.0 Sec	Run	A	o2-09*
C1-09	0208h	Fast Stop Time		0.0 ~ 6000.0 Sec	0.1 Sec	30.0 Sec		A	
C1-11	020Ah	Acc/Dec SW Freq		0.0 ~ 200.0 Hz	0.1 Hz	0.0 Hz		A	
C2-01	020Bh	SCrv Acc @ Start		0.0 ~ 2.5 Sec	0.01 Sec	0.2 Sec		A	
C2-02	020Ch	SCrv Acc @ End		0.0 ~ 2.5 Sec	0.01 Sec	0.2 Sec		A	
C4-01	0215h	Torq Comp Gain		0.0 ~ 2.5	0.01	1	Run	A	
C4-02	0216h	Torq Comp Time		0 ~ 10000 ms	1 ms	200 ms		A	
C6-01	0223h	Normal Duty Sel	0	Heavy Duty	1	2		F	o2-09*
			1	Normal Duty 1					
			2	Normal Duty 2					
C6-02	0224h	CarrierFreq Sel	0h	Low Noise	1	6h		A	kVA*
			1h	Fc=2.0kHz					
			2h	Fc=5.0kHz					
			3h	Fc=8.0kHz					
			4h	Fc=10.0kHz					
			5h	Fc=12.5kHz					
			6h	Fc=15.0kHz					
			7h-Eh	Reserved					
Fh	Program								
C6-03	0225h	CarrierFreq Max		0.4 ~ 15.0 kHz	0.1 kHz	2.0 kHz		A	
C6-04	0226h	CarrierFreq Min	0	Heavy Duty	0.1 kHz	2.0 kHz		A	
			1	Normal Duty					
C6-05	0227h	CarrierFreq Gain		0 ~ 99	1	0		A	
C6-06	0228h	PWM Method	0	2/3 Pha Auto-Mod	1	0		F	
			1	2 Phase Modulate					
			2	3 Phase Modulate					
			3	Motor Audible 1					
			4	Motor Audible 2					
			5	Motor Audible 3					
6	Motor Audible 4								
C6-07	0229h	Phase SW level		0.5 ~ 3.0	0.1	1.5		F	
C6-08	022Ah	PWM on Time		1.0 ~ 5.0	0.1	3		F	

Prm	Adr	Function	Data	Limits / Selections	Inc	Default	Run	Acc	Dep
d1-01	0280h	Reference 1		0.0 ~ 400.0 Hz	0.01 Hz	0.0 Hz	Run	A	o2-09*
d1-02	0281h	Reference 2		0.0 ~ 400.0 Hz	0.01 Hz	0.0 Hz	Run	A	
d1-03	0282h	Reference 3		0.0 ~ 400.0 Hz	0.01 Hz	0.0 Hz	Run	A	
d1-04	0283h	Reference 4		0.0 ~ 400.0 Hz	0.01 Hz	0.0 Hz	Run	A	
d1-17	0292h	Jog Reference		0.0 ~ 400.0 Hz	0.01 Hz	6.0 Hz	Run	A	
d2-01	0289h	Ref Upper Limit		0.0 ~ 110.0 %	0.10%	100.00%		A	
d2-02	028Ah	Ref Lower Limit		0.0 ~ 110.0 %	0.10%	0.00%		A	
d2-03	0293h	Ref1 Lower Limit		0.0 ~ 110.0 %	0.10%	0.00%		A	
d3-01	0294h	Jump Freq 1		0.0 ~ 200.0 Hz	0.1 Hz	0.0 Hz		A	
d3-02	0295h	Jump Freq 2		0.0 ~ 200.0 Hz	0.1 Hz	0.0 Hz		A	
d3-03	0296h	Jump Freq 3		0.0 ~ 200.0 Hz	0.1 Hz	0.0 Hz		A	
d3-04	0297h	Jump Bandwidth		0.0 ~ 20.0 Hz	0.1 Hz	1.0 Hz		A	
d4-01	0298h	MOP Ref Memory	0	Disabled	1	0		A	
			1	Enabled					
d4-02	0299h	Trim Control Lvl		0 ~ 100 %	1%	10%		A	
E1-01	0300h	Input Voltage		155 ~ 255 VAC	1 VAC	240 VAC		A	KVA* o2-09*
E1-03	0302h	V/F Selection	0h	50 Hz	1	0Fh		A	
			1h	60 Hz Saturation					
			2h	50 Hz Saturation					
			3h	72 Hz					
			4h	50 Hz VT1					
			5h	50 Hz VT2					
			6h	60 Hz VT1					
			7h	60 Hz VT2					
			8h	50 Hz HST1					
			9h	50 Hz HST2					
			Ah	60 Hz HST1					
			Bh	60 Hz HST2					
			Ch	90 Hz					
			Dh	120 Hz					
			Eh	180 Hz					
			Fh	Custom V/F					
			10h	Custom w/o limit					
E1-04	0303h	Max Frequency		0.0 ~ 200.0 Hz	0.1 Hz	60.0 Hz		A	E1-03*
E1-05	0304h	Max Voltage		0.0 ~ 255.0 VAC (200/240VAC drives) 0.0 ~ 555.0VAC (400/480VAC drives)	0.1 VAC	240.0 VAC		A	E1-03* kVA o2-09*
E1-06	0305h	Base Frequency		0.0 ~ 200.0 Hz	0.1 Hz	60.0 Hz		A	E1-03*
E1-07	0306h	Mid Frequency A		0.0 ~ 200.0 Hz	0.1 Hz	3.0 Hz		A	E1-03*
E1-08	0307h	Mid Voltage A		0.0 ~ 255.0 VAC (200/240VAC drives) 0.0 ~ 555.0VAC (400/480VAC drives)	0.1 VAC	13.0 VAC		A	E1-03* kVA
E1-09	0308h	Min Frequency		0.0 ~ 200.0 Hz	0.1 Hz	1.5 Hz		A	E1-03*
E1-10	0309h	Min Voltage		0.0 ~ 255.0 VAC (200/240VAC drives) 0.0 ~ 555.0VAC (400/480VAC drives)	0.1 VAC	9.0 VAC		A	E1-03* kVA
E1-11	030Ah	Mid Frequency B		0.0 ~ 200.0 Hz	0.1 Hz	0.0 Hz		A	E1-03*
E1-12	030Bh	Mid Voltage B		0.0 ~ 255.0 VAC (200/240VAC drives) 0.0 ~ 555.0VAC (400/480VAC drives)	0.1 VAC	0.0 VAC		A	E1-03* kVA
E1-13	030Ch	Base Voltage		0.0 ~ 255.0 VAC (200/240VAC drives) 0.0 ~ 555.0VAC (400/480VAC drives)	0.1 VAC	240.0 VAC		A	E1-03* kVA
E2-01	030Eh	Motor Rated FLA		0.1 ~ 1500.0 A	0.1 A	14.0 A		A	kVA*
E2-02	030Fh	Motor Rated Slip		0.0 ~ 20.0 Hz	0.01 Hz	3.3 Hz		F	kVA*
E2-03	0310h	No-Load Current		0.0 ~ 1500.0 A	0.1 A	4.5 A		A	kVA*
E2-05	0312h	Term Resistance		0.0 ~ 65.0 Ohm	0.001 Ohm	0.771 Ohm		A	kVA*
E2-10	0317h	Tcomp Iron Loss		0 ~ 65535 W	1 W	0 W		F	
E2-11	0318h	Mtr Rated Power		0.0 ~ 650.0 kW	0.01 kW	0.4 kW		F	
F6-01	03A2h	Comm Bus Flt Sel	0	Ramp to Stop	1	0		A	
			1	Coast to Stop					
			2	Fast-Stop					
			3	Alarm Only					
F6-02	03A3h	EF0 Detection	0	Always Detected	1	0		A	
			1	Only During Run					
F6-03	03A4h	EF0 Fault Action	0	Ramp to Stop	1	1		A	
			1	Coast to Stop					
			2	Fast-Stop					
			3	Alarm Only					
F6-05	03A6h			0 ~ 1	1	0		A	

Prm	Adr	Function	Data	Limits / Selections	Inc	Default	Run	Acc	Dep							
H1-01	0400h	Terminal S3 Sel	0h	3-Wire Control		1	24h									
			1h	Local/Remote Sel												
			2h	Option/Inv Sel												
			3h	Multi-Step Ref 1												
			4h	Multi-Step Ref 2												
			6h	Jog Freq Ref												
			7h	Multi-Acc/Dec 1												
			8h	Ext BaseBlk N.O.												
			9h	Ext BaseBlk N.C.												
			Ah	Acc/Dec RampHold												
			Ch	Term A2 Enable												
			Fh	Term Not Used												
			10h	MOP Increase												
			11h	MOP Decrease												
			12h	Forward Jog												
			13h	Reverse Jog												
			14h	Fault Reset												
			15h	Fast-Stop N.O.												
			17h	Fast-Stop N.C.												
			18h	Timer Function												
			19h	PI Disable												
			1Bh	Program Lockout												
			1Ch	TrimCtl Increase												
			1Dh	TrimCtl Decrease												
			1Eh	Ref Sample Hold												
			20h	NO/Always Det	Ramp to Stop											
			21h	NC/Always Det	Ramp to Stop											
			22h	NO/During RUN	Ramp to Stop											
			23h	NC/During RUN	Ramp to Stop											
			24h	NO/Always Det	Coast to Stop											
			25h	NC/Always Det	Coast to Stop											
			26h	NO/During RUN	Coast to Stop											
			27h	NC/During RUN	Coast to Stop											
			28h	NO/Always Det	Fast Stop											
			29h	NC/Always Det	Fast Stop											
			2Ah	NO/During RUN	Fast Stop											
			2Bh	NC/During RUN	Fast Stop											
			2Ch	NO/Always Det	Alarm Only											
			2Dh	NC/Always Det	Alarm Only											
			2Eh	NO/During RUN	Alarm Only											
			2Fh	NC/During RUN	Alarm Only											
			30h	PI Intgrl Reset												
			31h	PI Intgrl Hold												
			34h	PI SFS Cancel												
			35h	Input Level Sel												
			36h	Option/Inv Sel 2												
			60h	Motor Preheat												
			61h	Speed Search 1												
			62h	Speed Search 2												
			64h	Speed Search 3												
			67h	Comm Test Mode												
			68h	HighSlipBraking												
			69h	JOG2												
			6Ah	Drive Enable												
			6Bh	Com/Inv Sel												
			6Ch	Com/Inv Sel 2												
			6Dh	AUTO Mode Sel												
			6Eh	HAND Mode Sel												
			70h	Bypass Drv Enbl												
			H1-02	0401h	Terminal S4 Sel						See H4-01	1	14h		A	
			H1-03	0402h	Terminal S5 Sel						See H4-01	1	03h		A	
			H1-04	0403h	Terminal S6 Sel						See H4-01	1	04h		A	
			H1-05	0404h	Terminal S7 Sel						See H4-01	1	06h		A	

Prm	Adr	Function	Data	Limits / Selections	Inc	Default	Run	Acc	Dep	
H2-01	040Bh	Term M1-M2 Sel	0h	During RUN 1	1	0h			A	
			1h	Zero Speed						
			2h	Fref/Fout Agree 1						
			3h	Fref/Set Agree 1						
			4h	Freq Detect 1						
			5h	Freq Detect 2						
			6h	Inverter Ready						
			7h	DC Bus Undervolt						
			8h	BaseBlk 1						
			9h	Option Reference						
			Ah	Remote/Auto Oper						
			Bh	Trq Det 1 N.O.						
			Ch	Loss of Ref						
			Dh	DB Overheat						
			Eh	Fault						
			Fh	Not Used						
			10h	Minor Fault						
			11h	Reset Cmd Active						
			12h	Timer Output						
			17h	Trq Det 1 N.C.						
1Eh	Restart Enabled									
1Fh	Overload (OL1)									
20h	OH Prealarm									
38h	Drive Enable									
39h	Waiting to Run									
3Ah	OH Freq Reduce									
3Bh	Run Src Com/Opt									
H2-02	040Ch	Term M3-M4 Sel		See H2-01	1	0Ah		A	o2-09*	
H3-02	0411h	Terminal A1 Gain		0.0 ~ 1000.0 %	0.10%	100.00%	Run	A		
H3-03	0412h	Terminal A1 Bias		-100.0 ~ 100.0 %	0.10%	0.00%	Run	A		
H3-08	0417h	Term A2 Signal	0	0-10 VDC	1	2			A	
			1	-10 +10 VDC						
			2	4-20 mA						
			3	0-20 mA						
H3-09	0418h	Terminal A2 Sel	0h	Frequency Bias	1	2h			A	o2-09*
			2h	Aux Reference						
			Bh	PI Feedback						
			Dh	Frequency Bias 2						
			Eh	Motor Temperature						
			16h	PI Differential						
1Fh	Reserved									
H3-10	0419h	Terminal A2 Gain		0.0 ~ 1000.0 %	0.10%	100.00%	Run	A		
H3-11	041Ah	Terminal A2 Bias		-100.0 ~ 100.0 %	0.10%	0.00%	Run	A		
H3-12	041Bh	Filter Avg Time		0.0 ~ 2.0 Sec	0.01 Sec	0.3 Sec		A		
H3-13	041Ch	TA1/A2 Select	0	Main Fref TA1	1	0			A	
			1	Main Fref TA2						
H4-01	041Dh	Terminal FM Sel	1h	Frequency Ref	1	02h			A	
			2h	Output Freq						
			3h	Output Current						
			6h	Output Voltage						
			7h	DC Bus Voltage						
			8h	Output kWatts						
			15h	Term A1 Level						
			16h	Term A2 Level						
			18h	Mot SEC Current						
			20h	SFS Output						
			24h	PI Feedback						
			31h	Not Used						
			36h	PI Input						
			37h	PI Output						
			38h	PI Setpoint						
			41h	Actual Fin Temp						
51h	Auto Mode Fref									
52h	Hand Mode Fref									
53h	PI Feedback 2									
H4-02	041Eh	Terminal FM Gain		0.0 ~ 1000.0 %	0.10%	100.00%	Run	A		
H4-03	041Fh	Terminal FM Bias		-110.0 ~ 110.0 %	0.10%	0.00%	Run	A		
H4-04	0420h	Terminal AM Sel		See H4-01	1	08h		A		
H4-05	0421h	Terminal AM Gain		0.0 ~ 1000.0 %	0.10%	50.00%	Run	A		
H4-06	0422h	Terminal AM Bias		-110.0 ~ 110.0 %	0.10%	0.00%	Run	A		
H4-07	0423h	AO Level Select1	0	0-10 VDC	1	0			A	
			1	-10 +10 VDC						
			2	4-20 mA						
H4-08	0424h	AO Level Select2	0	0-10 VDC	1	0			A	
			1	-10 +10 VDC						
			2	4-20 mA						

Prm	Adr	Function	Data	Limits / Selections	Inc	Default	Run	Acs	Dep
H5-01	0425h	Serial Comm Adr		0h ~ 20h	1	1fh		A	
H5-02	0426h	Serial Baud Rate	0	1200 Baud	1	3		A	
			1	2400 Baud					
			2	4800 Baud					
			3	9600 Baud					
H5-03	0427h	Serial Com Sel	0	No Parity	1	0		A	
			1	Even Parity					
			2	Odd Parity					
H5-04	0428h	Serial Fault Sel	0	Ramp to Stop	1	3		A	
			1	Coast to Stop					
			2	Fast-Stop					
			3	Alarm Only					
H5-05	0429h	Serial Flt Dtct	0	Disabled	1	1		A	
			1	Enabled					
H5-06	042Ah	Transmit WaitTIM		5 ~ 65 ms	1 ms	5 ms		A	
H5-07	042Bh	RTS Control Sel	0	Disabled	1	1		A	
			1	Enabled					
H5-08	0434h	Protocol Select	0	Memobus(Modbus)	1	0		A	
			1	N2 (Metasys)					
			2	FLN (APOGEE)					
H5-09	0435h	CE Detect Time		0.0 ~ 10.0 Sec	0.1 Sec	2.0 Sec		A	
L1-01	0480h	MOL Fault Select	0	Disabled	1	1		A	
			1	Std Fan Cooled					
L1-02	0481h	MOL Time Const		0.1 ~ 20.0 min	0.1 min	8.0 min		A	o2-09*
L1-03	0482h	Mtr OH Alarm Sel	0	Ramp to Stop	1	3		A	
			1	Coast to Stop					
			2	Fast-Stop					
			3	Alarm Only					
L1-04	0483h	Mtr OH Fault Sel	0	Ramp to Stop	1	1		A	
			1	Coast to Stop					
			2	Fast-Stop					
L1-05	0484h	Mtr Temp Filter		0.0 ~ 10.0 Sec	0.01 Sec	0.2 Sec		A	
L2-01	0485h	PwrL Selection	0	Disabled	1	2		A	o2-09*
			1	PwrL RideThru t					
			2	CPU Power Active					
L2-02	0486h	PwrL Ridethru t		0.0 ~ 25.5 Sec	0.1 Sec	0.1 Sec		A	kVA*
L2-03	0487h	PwrL Baseblock t		0.1 ~ 5.0 Sec	0.1 Sec	0.5 Sec		A	kVA*
L2-04	0488h	PwrL V/F Ramp t		0.0 ~ 5.0 Sec	0.1 Sec	0.3 Sec		A	kVA*
L2-05	0489h	PUV Det Level		150 ~ 210 VDC	1 VDC	190 VDC		A	
L3-01	048Fh	StallP Accel Sel	0	Disabled	1	1		A	
			1	General Purpose					
			2	Intelligent					
L3-02	0490h	StallP Accel Lvl		0 ~ 200 %	1%	120%		A	
L3-03	0491h	StallP CHP Lvl		0 ~ 100 %	1%	50%		F	
L3-04	0492h	StallP Decel Sel	0	Disabled	1	1		A	
			1	General Purpose					
			2	Intelligent					
			3	Stall prev w/R					
L3-05	0493h	StallP Run Sel	0	Disabled	1	1		A	
			1	Decel Time 1					
			2	Decel Time 2					
L3-06	0494h	StallP Run Level		30 ~ 200 %	1%	120%		A	
L3-07	0495h	StallP Gain		0.1 ~ 2.0	0.01	1		F	
L3-08	0496h	StallP Intg Time		10 ~ 250 ms	1 ms	100 ms		F	
L3-09	0497h	Decel Time Coef		1.0 ~ 5.0	0.1	1		F	
L3-10	0498h	StallP Decel Lvl		80 ~ 95 %	1%	92%		F	
L4-01	0499h	Spd Agree Level		0.0 ~ 200.0 Hz	0.1 Hz	0.0 Hz		A	
L4-02	049Ah	Spd Agree Width		0.0 ~ 20.0 Hz	0.1 Hz	2.0 Hz		A	
L4-05	049Dh	Ref Loss Sel	0	Stop	1	1		A	
			1	Run@ 80% PrevRef					
L4-06	04C2h	Fref at Floss		0.0 ~ 100.0 %	0.10%	80.00%		A	
L5-01	049Eh	Num of Restarts		0 ~ 10	1	0		A	
L5-02	049Fh	Restart Sel	0	No Flt Relay	1	0		A	
			1	Flt Relay Active					
L5-03	04A0h	Max Restart Time		0.5 ~ 180.0 Sec	0.1 Sec	180.0 Sec		A	o2-09*
L5-04	04C3h	Restart Mode Sel	0	Wait Time Mode	1	0		F	o2-09*
			1	Max Time Mode					

Prm	Adr	Function	Data	Limits / Selections	Inc	Default	Run	Acs	Dep
L6-01	04A1h	Torq Det 1 Sel	0	Disabled	1	0		A	o2-09*
			1	OL@SpdAgree-Alm					
			2	OL At RUN - Alm					
			3	OL@SpdAgree-Flt					
			4	OL At RUN - Flt					
			5	UL@SpdAgree-Alm					
			6	UL At RUN - Alm					
			7	UL@SpdAgree-Flt					
			8	UL At RUN - Flt					
L6-02	04A2h	Torq Det 1 Lvl	0 ~ 300 %		1%	15%		A	
L6-03	04A3h	Torq Det 1 Time	0.0 ~ 10.0 Sec		0.1 Sec	10.0 Sec		A	
L8-01	04ADh	DB Resistor Prot	0	Not Provided	1	0		F	
			1	Provided					
L8-02	04AEh	OH Pre-Alarm Lvl	50 ~ 130 Deg		1 Deg	95 Deg		A	kVA*
L8-03	04AFh	OH Pre-Alarm Sel	0	Ramp to Stop	1	4		A	
			1	Coast to Stop					
			2	Fast-Stop					
			3	Alarm Only					
			4	OH Alarm&Reduce					
L8-04	04B0h	OH1 Fault Level	50 ~ 130 Deg		1 Deg	105 Deg		F	kVA*
L8-05	04B1h	Ph Loss In Sel	0	Disabled	1	1		F	o2-09*
			1	Enabled					
L8-06	04B2h	Ph Loss In Lvl	0.0 ~ 25.0 %		0.10%	7.50%		A	kVA*
L8-07	04B3h	Ph Loss Out Sel	0	Disabled	1	1		F	o2-09*
			1	Enabled					
L8-08	04B4h	Ph Loss Out Lvl	0.0 ~ 20.0 %		0.10%	5.00%		F	
L8-09	04B5h	Ground Fault Sel	0	Disabled	1	1		A	
			1	Enabled					
L8-10	04B6h	Fan On/Off Sel	0	Fan On-Run Mode	1	0		A	
			1	Fan Always On					
L8-11	04B7h	Fan Delay Time	0	Disabled	1	300 Sec		A	
			1	Enabled					
L8-12	04B8h	Ambient Temp	45 ~ 60 Deg		1 Deg	45 Deg		A	
L8-13	04B9h	UV3 Detect	0	Disabled	1	1		F	
			1	Enabled					
L8-14	04BAh	Inverter OL Sel	0	Disabled	1	0		F	
			1	Enabled					
L8-15	04BBh	OL2 Sel @ L-Spd	0	Disabled	1	1		A	L8-16
			1	Enabled					
L8-16	04BCh	Low Spd OL2 Freq	0	Disabled	0.1 Hz	0.1 Hz		F	
			1	Enabled					
L8-17	04BDh	OL2 0Hz Gain	0	Disabled	1%	60%		F	
			1	Enabled					
L8-18	04BEh	Soft CLA Sel	0	Disabled	1	1		A	
			1	Enabled					
L8-19	04BFh	Fref During OH	0.0 ~ 100.0 %		0.10%	20.00%		A	
n1-01	0580h	Hunt Prev Select	0	Disabled	1	1		A	
			1	Enabled					
n1-02	0581h	Hunt Prev Gain	0.0 ~ 2.5		0.01	1		A	
n1-03	0582h	Hunt Prev Time	0 ~ 500 ms		1 ms	10 ms		F	kVA*
n1-04	0583h	Hunt Prev Limit	0 ~ 100 %		1%	5%		F	
n3-01	0588h	HSB Decel Width	1 ~ 20 %		1%	5%		A	
n3-02	0589h	HSB Current Ref	100 ~ 200 %		1%	150%		A	
n3-03	058Ah	HSB DwelTim@Stp	0.0 ~ 10.0 Sec		0.1 Sec	1.0 Sec		A	
n3-04	058Bh	HSB OL Time	30 ~ 1200 Sec		1 Sec	40 Sec		A	
n3-05	058Ch	HSB V/F Gain	1 ~ 50 %		1%	5%		F	
n3-06	058Dh	Spd Agr Current	0 ~ 100 %		1%	50%		F	
n3-07	058Eh	Spd Agree Time	100 ~ 2000 ms		1 ms	800 ms		F	
n3-08	058Fh	HSB V Lvl1	80 ~ 90 %		1%	87%		F	
n3-09	0590h	HSB V Lvl2	90 ~ 95 %		1%	92%		F	
n3-10	0591h	HSB RI Comp Coef	20 ~ 100 %		1%	50%		F	
n3-11	0592h	HSB RI Comp Tim	10 ~ 1000 ms		1 ms	200 ms		F	
n3-12	0593h	Prohib HSB Decel	0 ~ 20 Hz		1 Hz	6 Hz		F	
n9-01	05D0h	Inv Rate Current	0.0 ~ 1500.0 A		0.1 A	0.0 A		F	kVA*
n9-02	05D1h	DCCT Gain	0.0 ~ 2.0		0.001	0		F	kVA*
n9-09	05D8h	AVR Selection	0	Disabled	1	1		F	
			1	Enabled					
			2	Stabilize					
n9-10	05D9h	AVR Time	0.0 ~ 100.0 ms		0.1 ms	1.0 ms		F	
n9-11	05DAh	ON-Delay Time	2.5 ~ 18.0 us		0.1 us	3.0 us		F	kVA*
n9-12	05DBh	ON-Delay Comp	0.0 ~ 20.0 us		0.1 us	3.0 us		F	kVA*
n9-13	05DCh	IGBT Volt Drop	0.0 ~ 10.0 VDC		0.1 VDC	0.0 VDC		F	
n9-14	05DDh	Pwr Angle Filt 1	0 ~ 1000 ms		1 ms	5 ms		F	kVA*
n9-15	05DEh	Pwr Angle Filt 2	0 ~ 1000 ms		1 ms	5 ms		F	
n9-19	05E2h	DCCT Filter Time	-1000 ~ 1000 us		1 us	0 us		F	

Prm	Adr	Function	Data	Limits / Selections	Inc	Default	Run	Acc	Dep
n9-20	05E3h	Soft CLA Gain		0.0 ~ 4.0	0.01	2		F	
n9-21	05E4h	Soft CLA Filter		0.0 ~ 100.0 ms	0.1 ms	0.5 ms		F	
n9-22	05E5h	Soft CLA Level1		0.0 ~ 300.0 %	0.10%	120.00%		F	
n9-23	05E6h	Soft CLA Level2		0.0 ~ 300.0 %	0.10%	120.00%		F	
n9-24	05E7h	Soft CLA SW Freq		0.0 ~ 100.0 Hz	0.1 Hz	6.0 Hz		F	
n9-25	05E8h	Soft CLA Level3		0.0 ~ 300.0 %	0.10%	300.00%		F	
n9-26	05E9h	OnDelay Comp Lvl		0.0 ~ 10.0 %	0.10%	2.00%		F	kVA*
n9-27	05EAh	IGBT Gain		0.0 ~ 2.0	0.01	0		F	kVA*
n9-28	05EBh	Aging Test Mode	0	Disabled	1	0		F	
			1	Enabled					
o1-01	0500h	User Monitor Sel		See H4-01	1	6	Run	A	
o1-02	0501h	Power-On Monitor	0	Frequency Ref	1	1	Run	A	
			1	Output Freq					
			2	Output Current					
			3	User Monitor					
o1-03	0502h	Display Scaling	0	0.00 Hz	1	0		A	
			1	0.00 % (100.00% = Fmax)					
			2 ~ 39	RPM (Number of Motor Poles)					
			40 ~ 39999	Custom					

o2-04	0508h	Inverter Model #	00h	20P4	0.4kW	1	0h	A	
			01h	20P7	0.7kW				
			02h	21P5	1.5kW				
			03h	22P2	2.2kW				
			04h	23P7	3.7kW				
			05h	25P5	5.5kW				
			06h	27P5	7.5kW				
			07h	2011	11kW				
			08h	2015	15kW				
			09h	2018	17.5kW				
			0Ah	2022	22kW				
			0Bh	2030	30kW				
			0Ch	2037	37kW				
			0Dh	2045	45kW				
			0Eh	2055	55kW				
			0Fh	2075	75kW				
			10h	2090	90kW				
			11h	2110	110kW				
			20h	40P4	0.4kW				
			21h	40P7	0.7kW				
			22h	41P5	1.5kW				
			23h	42P2	2.2kW				
			24h	43P7	3.7kW				
			25h	44P0	4kW				
			26h	45P5	5.5kW				
			27h	47P5	7.5kW				
			28h	4011	11kW				
			29h	4015	15kW				
			2Ah	4018	17.5kW				
			2Bh	4022	22kW				
			2Ch	4030	30kW				
			2Dh	4037	37kW				
			2Eh	4045	45kW				
			2Fh	4055	55kW				
30h	4075	75kW							
31h	4090	90kW							
32h	4110	110kW							
33h	4132	132kW							
34h	4160	160kW							
35h	4185	185kW							
3Eh	4200	200kW							
36h	4220	220kW							
37h	4300	300kW							

o2-05	0509h	Operator M.O.P.	0	Disabled	1	1		A	o2-09*
			1	Enabled					

Prm	Adr	Function	Data	Limits / Selections	Inc	Default	Run	Acs	Dep
o2-06	050Ah	Oper Detection	0	Disabled	1	1		A	o2-09*
			1	Enabled					
o2-07	050Bh	Elapsed Time Set		0 ~ 65535 H	1 H	0 H		A	
o2-08	050Ch	Elapsed Time Run	0	Power-On Time	1	1		A	o2-09*
			1	Running Time					
o2-09	050Dh	Init Mode Sel	0	Japanese spec	1	1		A	o2-09*
			1	American spec					
			2	European spec					
			4	PV-A spec					
			5	PV-E spec					
o2-10	050Eh	Fan ON Time Set		0 ~ 65535 H	1 H	0 H		A	
o2-12	0510h	FLT Trace Init	0	Disabled	1	0		A	
			1	Enabled					
o2-13	0511h	PUF Cont det Sel	0	Disabled	1	1		F	
			1	Enabled					
o2-14	0512h	kWh MonitorClear	0	No Change	1	0		A	
			1	Clear All					
o2-15	0513h	Oper HAND Key	0	Disabled	1	1		A	o2-09*
			1	Enabled					
o3-01	0515h	Copy Funtion Sel	0	COPY SELECT	1	0		A	
			1	INV~OP READ					
			2	OP~INV WRITE					
			3	OP~INV VERIFY					
o3-02	0516h	Read Allowable	0	Disabled	1	0		A	
			1	Enabled					
T1-01	0701h	Tuning Mode Sel	0	Motor Setup(REV)	1	0		A	
			1	Tune w/o Rotate					
			2	Term Resistance					
T1-02	0702h	Mtr Rated Power		0.0 ~ 650.0 kW	0.01 kW	0.0 kW		A	
T1-04	0704h	Rated Current		0.0 ~ 1500.0 A	0.1 A	0.0 A		A	

ENTER/ACCEPT Command (Write Only)

Caution

Data sent to the E7 drive serially, is sent to the E7 drive's RAM and may be lost when the E7 drive loses power. In order for this data to be retained upon power loss, it must be first transferred to non-volatile memory. The ENTER command transfers the current RAM parameter data to non-volatile memory. Caution should be exercised when using the ENTER command as the maximum number of non-volatile memory writes cannot exceed 100,000. Excessive use of the ENTER command will cause the E7 drive to fail. Entering data through the digital operator transfers the data to non-volatile memory without the use of the ENTER command. Data that cannot be changed while the E7 drive is in RUN mode, is stored in a temporary location. The ACCEPT command is used to move that data from temporary storage to active RAM. There is no restriction on the use of the ACCEPT command.

Table 4.5 - ENTER Command			
Addr	Function	Data	Description
910	ACCEPT	0	Transfer data to active RAM
900	ENTER	0	Transfers the current parameter data to non-volatile storage

Parameter Dependencies

Certain E7 drive parameters, Master parameters, can affect the default values, range of values and accessibility of other, dependent, parameters. When a Master parameter's value is changed via serial communications (RS232, RS485, DeviceNet, Ethernet, etc.), the associated dependent parameters are not automatically updated and must be updated serially. For example, parameter d2-02 (frequency lower limit) affects the range of values for all frequency reference parameters (d1-01 through d1-17). If d2-02 is changed to 5.0Hz serially, all frequency reference parameters with values below 5.0Hz must be updated serially to have current values of 5.0Hz or greater. An E7 drive fault may occur if a dependent parameter's values are not updated.

The standard sequence for changing E7 drive parameters is

- Set A1-01 to 2 - Set the access value to Advanced
- Set Master parameter to desired value
- Send ENTER command
- Set any dependent parameter values
- Send ENTER command.

► Master Parameter Sequence Numbers

Some E7 drive parameters may be dependent on more than one Master parameter. For example o2-04 (kVA) and o2-09 (specification) affect a number of parameters together. In these cases it is necessary that the parameter with the lowest sequence number be changed first. The sequence table is shown below. Sequence numbers range from 1 through 9 with lower sequence parameters being changed before parameters with higher sequence numbers. In all cases the parameter access level (A1-02) should be changed to 2 first. Shaded parameters are factory set and are provided for information purposes only.

Prm	Seq	Name	Action after parameter change
o2-04	1	kVA or E7 drive Model	Send ENTER command, power cycle E7 drive, change dependent parameters, send ENTER If o2-09 is also going to be changed, set o2-09 before setting dependent or slave parameter values
o2-09	2	Initialization Mode	Send ENTER Change dependent parameters Send ENTER
C6-01	4	Heavy/Normal Duty	
C6-02	5	Carrier Frequency	
d2-01	5	Freq Upper Limit	
d2-02	5	Freq Lower Limit	
E1-01	5	Input Voltage	

► o2-04 kVA Parameter Dependencies

E7 drive kVA or model is set at the factory and should **NOT** be changed. These values are included for information purposes only. Shaded parameters are factory set and are provided for information purposes only.

Model		20P4	20P7	21P5	22P2	23P7	25P5	27P5	2011	2015	2018	2022	2030	2037	2045	2055	2075	2090
kW		0.4	0.75	1.5	2.2	3.7	5.5	7.5	11	15	18.5	22	30	37	45	55	75	90
Min VAC		155	155	155	155	155	155	155	155	155	155	155	155	155	155	155	155	155
Max VAC		255	255	255	255	255	255	255	255	255	255	255	255	255	255	255	255	255
Param	Units	0	1	2	3	4	5	6	7	8	9	0A	0B	0C	0D	0E	0F	10
b3-03	Sec	2.0	2.0	2.0	2.0	2.0	2.0	2.0	2.0	2.0	2.0	2.0	2.0	2.0	2.0	2.0	2.0	2.0
b3-04	%	100	100	100	100	100	100	100	100	100	100	100	80	80	80	80	80	80
b3-06		0.5	0.5	0.5	0.5	0.5	0.5	0.5	0.5	0.5	0.5	0.5	0.5	0.5	0.5	0.5	0.7	0.7
b3-08		5.0	5.0	5.0	5.0	5.0	5.0	5.0	5.0	5.0	5.0	5.0	5.0	5.0	5.0	5.0	5.0	5.0
b8-04		288.20	223.70	169.40	156.80	122.90	94.75	72.69	70.44	63.13	57.87	51.79	46.27	38.16	35.78	31.35	23.10	20.65
C6-02		6	6	6	6	6	6	6	6	6	6	6	4	3	3	3	2	2
C6-02 VT2		4	4	4	3	4	6	6	3	4	4	4	4	2	2	3	1	1
C6-03 U-lim		15.0	15.0	15.0	15.0	15.0	15.0	15.0	15.0	15.0	15.0	15.0	15.0	10.0	10.0	10.0	10.0	10.0
E2-01	A	1.9	3.3	6.2	8.5	14.0	19.6	26.6	39.7	53.0	65.8	77.2	105.0	131.0	160.0	190.0	260.0	260.0
E2-02	Hz	2.90	2.50	2.60	2.90	2.73	1.50	1.30	1.70	1.60	1.67	1.70	1.80	1.33	1.60	1.43	1.39	1.39
E2-03	A	1.2	1.8	2.8	3.0	4.5	5.1	8.0	11.2	15.2	15.7	18.5	21.9	38.2	44.0	45.6	72.0	72.0
E2-05	Ohm	9.842	5.156	1.997	1.601	0.771	0.399	0.288	0.230	0.138	0.101	0.079	0.064	0.039	0.030	0.022	0.023	0.023
L2-02	Sec	0.1	0.1	0.2	0.3	0.5	1.0	1.0	1.0	2.0	2.0	2.0	2.0	2.0	2.0	2.0	2.0	2.0
L2-03	Sec	0.1	0.2	0.3	0.4	0.5	0.6	0.7	0.8	0.9	1.0	1.0	1.1	1.1	1.2	1.2	1.3	1.5
L2-04	Sec	0.3	0.3	0.3	0.3	0.3	0.3	0.3	0.3	0.3	0.6	0.6	0.6	0.6	0.6	1.0	1.0	1.0
L8-02	Deg C	95	95	95	100	95	95	95	95	90	100	90	90	95	100	105	110	100
L8-04	Deg C	105	105	105	110	105	105	105	105	100	110	100	100	105	110	115	120	110
L8-06	%	5.0	7.5	10.0	12.0	12.0	10.0	17.0	21.0	17.0	15.0	24.0	20.0	18.0	20.0	17.0	16.0	18.0
n1-03	ms	10	10	10	10	10	10	10	10	10	10	10	10	10	10	10	10	100
n9-01	A	3.2	4.1	7.0	9.6	15.0	23.0	31.0	45.0	58.0	71.0	85.0	115.0	145.0	180.0	215.0	283.0	346.0
n9-01 VT2	A	3.6	4.6	7.8	10.8	16.8	23.0	31.0	46.2	59.4	74.8	88.0	115.0	162.0	192.0	215.0	312.0	360.0
n9-02		1.002	1.283	1.167	1.202	1.251	1.273	1.149	1.273	1.214	1.076	1.064	1.213	1.116	1.125	1.174	1.249	1.154
n9-11	us	2.0	2.0	2.0	2.0	2.0	2.0	2.0	2.0	2.0	2.0	2.0	2.0	3.0	3.0	3.0	3.0	3.0
n9-11 L-lim	us	1.5	1.5	1.5	1.5	1.5	1.5	1.5	1.5	1.5	1.5	1.5	1.5	2.5	2.5	2.5	2.5	2.5
n9-12	us	2.6	2.6	2.6	2.6	2.6	2.6	2.6	2.3	2.3	2.3	2.3	2.3	3.4	2.5	2.5	3.2	2.0
n9-14	ms	20	20	20	20	20	20	20	20	20	20	20	20	20	20	20	20	20
n9-26	%	15.0	15.0	15.0	15.0	15.0	15.0	15.0	15.0	15.0	15.0	15.0	15.0	15.0	15.0	15.0	15.0	15.0
n9-27		0.45	0.58	0.66	0.68	0.71	0.65	0.58	0.85	0.82	0.67	0.60	0.81	0.68	0.64	0.76	0.67	0.61

Table 4.8 – kVA Dependencies

Model		2110	40P4	40P7	41P5	42P4	43P7	44P0	45P5	47P5	4011	4015	4018	4022	4030	4037	4045	4055
kW		110	0.4	0.75	1.5	2.2	3.7	4	5.5	7.5	11	15	18.5	22	30	37	45	55
Min VAC		155	355	355	355	355	355	355	355	355	355	355	355	355	355	355	355	355
Max VAC		255	555	555	555	555	555	555	555	555	555	555	555	555	555	555	555	555
Param	Units	11	20	21	22	23	24	25	26	27	28	29	2A	2B	2C	2D	2E	2F
b3-03	Sec	2.0	2.0	2.0	2.0	2.0	2.0	2.0	2.0	2.0	2.0	2.0	2.0	2.0	2.0	2.0	2.0	2.0
b3-04	%	80	100	100	100	100	100	100	100	100	100	100	100	100	100	100	100	80
b3-06		0.7	0.5	0.5	0.5	0.5	0.5	0.5	0.5	0.5	0.5	0.5	0.5	0.5	0.5	0.5	0.5	0.5
b3-08		5.0	5.0	5.0	5.0	5.0	5.0	5.0	5.0	5.0	5.0	5.0	5.0	5.0	5.0	5.0	5.0	5.0
b8-04		18.12	576.40	447.40	338.80	313.60	245.80	236.44	189.50	145.38	140.88	126.26	115.74	103.58	92.54	76.32	71.56	67.20
C6-02		1	6	6	6	6	6	6	6	6	6	6	6	6	4	4	4	4
C6-02 VT2		1	6	6	6	6	6	6	6	6	3	4	4	4	3	3	3	2
C6-03 U-lim		2.5	15.0	15.0	15.0	15.0	15.0	15.0	15.0	15.0	15.0	15.0	15.0	15.0	15.0	15.0	15.0	15.0
E2-01	A	260.0	1.0	1.6	3.1	4.2	7.0	7.0	9.8	13.3	19.9	26.5	32.9	38.6	52.3	65.6	79.7	95.0
E2-02	Hz	1.39	2.90	2.60	2.50	3.00	2.70	2.70	1.50	1.30	1.70	1.60	1.67	1.70	1.80	1.33	1.60	1.46
E2-03	A	72.0	0.6	0.8	1.4	1.5	2.3	2.3	2.6	4.0	5.6	7.6	7.8	9.2	10.9	19.1	22.0	24.0
E2-05	Ohm	0.023	38.198	22.459	10.100	6.495	3.333	3.333	1.595	1.152	0.922	0.550	0.403	0.316	0.269	0.155	0.122	0.088
L2-02	Sec	2.0	0.1	0.1	0.2	0.3	0.5	0.5	0.8	0.8	1.0	2.0	2.0	2.0	2.0	2.0	2.0	2.0
L2-03	Sec	1.7	0.1	0.2	0.3	0.4	0.5	0.6	0.6	0.7	0.8	0.9	1.0	1.0	1.1	1.1	1.2	1.2
L2-04	Sec	1.0	0.3	0.3	0.3	0.3	0.3	0.3	0.3	0.3	0.3	0.3	0.6	0.6	0.6	0.6	0.6	1.0
L8-02	Deg C	110	95	95	95	90	95	95	95	90	95	95	98	78	85	85	90	90
L8-04	Deg C	120	105	105	105	100	105	105	105	100	105	105	108	88	95	95	100	100
L8-06	%	20.0	0.50	0.75	10.0	10.0	12.0	10.0	10.0	20.0	23.0	17.0	17.0	20.0	20.0	20.0	20.0	20.0
n1-03	ms	100	10	10	10	10	10	10	10	10	10	10	10	10	10	10	10	30
n9-01	A	415.0	1.8	2.1	3.7	5.3	7.6	8.7	12.5	17.0	24.0	31.0	39.0	45.0	60.0	75.0	91.0	112.0
n9-01 VT2	A	4150	1.8	2.1	3.7	5.3	7.6	8.7	12.5	17.0	27.0	34.0	40.0	50.4	67.2	77.0	96.0	125.0
n9-02		1.093	0.529	0.617	1.087	1.106	1.224	0.966	1.136	1.133	1.143	1.149	1.146	1.074	1.255	1.155	1.139	1.180
n9-11	us	4.0	2.0	2.0	2.0	2.0	2.0	2.0	2.0	2.0	2.0	2.0	2.0	2.0	2.0	2.0	2.0	2.0
n9-11 L-lim	us	3.5	1.5	1.5	1.5	1.5	1.5	1.5	1.5	1.5	1.5	1.5	1.5	1.5	1.5	1.5	1.5	1.5
n9-12	us	2.6	2.3	2.3	2.	2.5	2.5	2.2	2.2	2.2	2.2	2.2	2.4	2.4	2.4	2.4	2.9	2.9
n9-14	ms	20	20	20	20	20	20	20	20	20	20	20	20	20	20	20	20	20
n9-26	%	0.0	40.0	40.0	40.0	40.0	40.0	70.0	70.0	70.0	30.0	30.0	30.0	30.0	30.0	15.0	15.0	15.0
n9-27		0.49	0.25	0.30	0.52	0.75	0.72	0.49	0.71	0.69	0.68	0.58	0.74	0.64	0.85	0.71	0.64	0.79

Table 4.9 – kVA Dependencies																				
Model		4075	4090	4110	4132	4160	4185	4220	4300	4200										
kW		75	90	110	132	160	185	220	300	200										
Min VAC		355	355	355	355	355	355	355	355	355										
Max VAC		555	555	555	555	555	555	555	555	555										
Param	Units	30	31	32	33	34	35	36	37	3E										
b3-03	Sec	2.0	2.0	2.0	2.0	2.0	2.0	2.0	2.0	2.0										
b3-04	%	60	60	60	60	60	60	60	60	60										
b3-06		0.7	0.7	0.7	0.7	0.7	0.7	0.7	0.7	0.7										
b3-08		8.0	8.0	8.0	8.0	8.0	8.0	8.0	8.0	8.0										
b8-04		46.20	38.91	36.23	32.79	30.13	30.57	27.13	21.76	0										
C6-02		3	3	3	2	2	2	1	1	1										
C6-02 VT2		2	3	2	2	2	1	1	1	1										
C6-03 U-lim		10.0	10.0	10.0	10.0	10.0	5.0	2.5	2.5	2.0										
E2-01	A	130.0	156.0	190.0	223.0	270.0	310.0	370.0	500.0	370.0										
E2-02	Hz	1.39	1.40	1.40	1.38	1.35	1.30	1.30	1.25	1.30										
E2-03	A	36.0	40.0	49.0	58.0	70.0	81.0	96.0	130.0	96.0										
E2-05	Ohm	0.092	0.056	0.046	0.035	0.029	0.025	0.020	0.014	0.020										
L2-02	Sec	2.0	2.0	2.0	2.0	2.0	2.0	2.0	2.0	2.0										
L2-03	Sec	1.3	1.5	1.7	1.7	1.8	1.9	2.0	2.1	2.0										
L2-04	Sec	1.0	1.0	1.0	1.0	1.0	1.0	1.0	1.0	1.0										
L8-02	Deg C	98	108	100	110	108	95	100	108	95										
L8-04	Deg C	108	118	110	120	118	105	110	118	105										
L8-06	%	16.0	16.0	16.0	16.0	14.0	15.0	15.0	15.0	N/A										
n1-03	ms	30	30	30	30	30	30	30	30	30										
n9-01	A	150.0	180.0	216.0	260.0	304.0	370.0	506.0	675.0	414.0										
n9-01 VT2	A	156.0	180.0	240.0	260.0	304.0	414.0	515.0	675.0	414.0										
n9-02		11.69	10.91	11.38	10.85	11.27	11.39	10.73	10.31	11.92										
n9-11	us	3.0	3.0	3.0	3.0	3.0	3.0	3.0	3.0	3.0										
n9-11 L-lim	us	2.5	2.5	2.5	2.5	2.5	2.5	2.5	2.5	2.5										
n9-12	us	2.2	2.0	2.0	1.8	2.0	2.5	3.3	3.7	4.0										
n9-14	ms	20	20	20	20	20	4	4	4	4										
n9-26	%	15.0	15.0	15.0	15.0	15.0	15.0	15.0	15.0	15.0										
n9-27		0.71	0.64	0.76	0.61	0.72	0.65	0.60	0.80	1.00										

► o2-09 Specification

After the kVA parameters, these are the most important and are the next highest of the sequence numbers. The table below lists those parameters that are affected by setting parameter o2-09.

The “Other” column

- N/A - that parameter is not available under that specification
- Shaded - parameter is factory accessible and shown for information purposes only

Parameter	Units	F7A	E7U	E7C	PV-A	PV-E
b1-04		0	1	0	1	0
b2-04	Sec	0.50	0.0	0.50	0.0	0.50
b5-02		1.00	2.00	1.00	2.00	1.00
b5-03	Sec	1.0	5.0	1.0	5.0	1.0
C1-01	Sec	10.0	30.0	10.0	30.0	10.0
C1-02	Sec	10.0	30.0	10.0	30.0	10.0
C1-03	Sec	10.0	30.0	10.0	30.0	10.0
C1-04	Sec	10.0	30.0	10.0	30.0	10.0
C6-01		1	2	1	2	1
d1-01	Hz	0.0	0.0	0.0	0.0	0.0
E1-01	VAC	200	240	200	240	200
E1-05	VAC	200.0	240.0	200.0	240.0	200.0
H2-02		1	0Ah	1	0Ah	1
H3-09		0	2	0	2	0
L1-02	min	1.0	8.0	1.0	8.0	1.0
L2-01		0	2	0	2	0
L5-03	Sec	10.0	180.0	10.0	180.0	10.0
L5-04		1	0	1	0	1
L6-01		0	0	6	0	6
L8-05		0	1	1	1	1
L8-07		0	1	0	1	0
o2-05		0	1	0	1	0
o2-06		0	1	0	1	0
o2-08		0	1	1	1	1
o2-09		0	1	2	4	5
o2-15		0	1	0	1	0

► E1-03 V/f Pattern Selection

The relationship of the parameters in the V/f patterns is shown below. For custom settings make sure that

$$E1-09 \leq E1-07 \leq E1-06 \leq E1-11 \leq E1-04$$

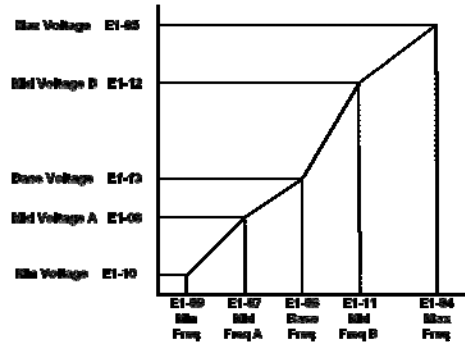

Table 4.12 – E1-03 V/f Pattern Selection

200VAC										
E1-03	E1-04	E1-05	E1-06	E1-07	E1-08	E1-09	E1-10	E1-11	E1-12	E1-13
00H	50.0	20.00	50.0	2.5	15.0	1.3	9.0	0.0	0.0	0.0
01H	60.0	20.00	60.0	3.0	15.0	1.5	9.0	0.0	0.0	0.0
02H	60.0	20.00	50.0	3.0	15.0	1.5	9.0	0.0	0.0	0.0
03H	72.0	20.00	60.0	3.0	15.0	1.5	9.0	0.0	0.0	0.0
04H	50.0	20.00	50.0	25.0	35.0	1.3	8.0	0.0	0.0	0.0
05H	50.0	20.00	50.0	25.0	50.0	1.3	9.0	0.0	0.0	0.0
06H	60.0	20.00	60.0	30.0	35.0	1.5	8.0	0.0	0.0	0.0
07H	60.0	20.00	60.0	30.0	50.0	1.5	9.0	0.0	0.0	0.0
08H	50.0	20.00	50.0	2.5	19.0	1.3	11.0	0.0	0.0	0.0
09H	50.0	20.00	50.0	2.5	24.0	1.3	13.0	0.0	0.0	0.0
0AH	60.0	20.00	60.0	3.0	19.0	1.5	11.0	0.0	0.0	0.0
0BH	60.0	20.00	60.0	3.0	24.0	1.5	15.0	0.0	0.0	0.0
0CH	90.0	20.00	60.0	3.0	15.0	1.5	9.0	0.0	0.0	0.0
0DH	120.0	20.00	60.0	3.0	15.0	1.5	9.0	0.0	0.0	0.0
0EH	180.0	20.00	60.0	3.0	15.0	1.5	9.0	0.0	0.0	0.0
0FH	60.0	20.00	60.0	30.	15.0	1.5	9.0	0.0	0.0	0.0

400VAC										
E1-03	E1-04	E1-05	E1-06	E1-07	E1-08	E1-09	E1-10	E1-11	E1-12	E1-13
00H	50.0	20.00	50.0	25	14.0	1.3	7.0	0.0	0.0	0.0
01H	60.0	20.00	60.0	3.0	14.0	1.5	7.0	0.0	0.0	0.0
02H	60.0	20.00	50.0	3.0	14.0	1.5	7.0	0.0	0.0	0.0
03H	72.0	20.00	60.0	3.0	14.0	1.5	7.0	0.0	0.0	0.0
04H	50.0	20.00	50.0	25.0	35.0	1.3	6.0	0.0	0.0	0.0
05H	50.0	20.00	50.0	25.0	50.0	1.3	7.0	0.0	0.0	0.0
06H	60.0	20.00	60.0	30.0	35.0	1.5	6.0	0.0	0.0	0.0
07H	60.0	20.00	60.0	30.0	50.0	1.5	7.0	0.0	0.0	0.0
08H	50.0	20.00	50.0	2.5	18.0	1.3	9.0	0.0	0.0	0.0
09H	50.0	20.00	50.0	2.5	23.0	1.3	11.0	0.0	0.0	0.0
0AH	60.0	20.00	60.0	3.0	18.0	1.5	9.0	0.0	0.0	0.0
0BH	60.0	20.00	60.0	3.0	23.0	1.5	13.0	0.0	0.0	0.0
0CH	90.0	20.00	60.0	3.0	14.0	1.5	7.0	0.0	0.0	0.0
0DH	120.0	20.00	60.0	3.0	14.0	1.5	7.0	0.0	0.0	0.0
0EH	180.0	20.00	60.0	3.0	14.0	1.5	7.0	0.0	0.0	0.0
0FH	60.0	20.00	60.0	3.0	14.0	1.5	7.0	0.0	0.0	0.0

This page intentionally left blank.

Chapter 5 User Notes

This chapter allows the user to enter information specific to their application

Parameter Record.....	5 - 3
Notes	5 - 11
Hex/Dec Conversion Table.....	5 - 12

This page intentionally left blank.

Parameter Record

Table 5.1- Registers Notes			
Prm	Function	Default	Notes
A1-00	Select Language	0	
A1-01	Access Level	2	
A1-03	Init Parameters	0	
A1-04	Enter Password	0	
A2-01	User Param 1	0h	
A2-02	User Param 2	0h	
A2-03	User Param 3	0h	
A2-04	User Param 4	0h	
A2-05	User Param 5	0h	
A2-06	User Param 6	0h	
A2-07	User Param 7	0h	
A2-08	User Param 8	0h	
A2-09	User Param 9	0h	
A2-10	User Param 10	0h	
A2-11	User Param 11	0h	
A2-12	User Param 12	0h	
A2-13	User Param 13	0h	
A2-14	User Param 14	0h	
A2-15	User Param 15	0h	
A2-16	User Param 16	0h	
A2-17	User Param 17	0h	
A2-18	User Param 18	0h	
A2-19	User Param 19	0h	
A2-20	User Param 20	0h	
A2-21	User Param 21	0h	
A2-22	User Param 22	0h	
A2-23	User Param 23	0h	
A2-24	User Param 24	0h	
A2-25	User Param 25	0h	
A2-26	User Param 26	0h	
A2-27	User Param 27	0h	
A2-28	User Param 28	0h	
A2-29	User Param 29	0h	
A2-30	User Param 30	0h	
A2-31	User Param 31	0h	
A2-32	User Param 32	0h	

Table 5.1- Registers Notes

Prm	Function	Default	Notes
b1-01	Reference Source	1	
b1-02	Run Source	1	
b1-03	Stopping Method	0	
b1-04	Reverse Oper	1	
b1-07	LOC/REM RUN Sel	0	
b1-08	RUN CMD at PRG	0	
b1-11	Wait to Run Time	0 Sec	
b1-12	HAND Fref Source	0	
b2-01	DCInj Start Freq	0.5 Hz	
b2-02	DCInj Current	50%	
b2-03	DCInj Time@Start	0.0 Sec	
b2-04	DCInj Time@Stop	0.0 Sec	
b2-09	Preheat Current	0%	
b3-01	SpdSrch at Start	0	
b3-02	SpdSrch Current	120%	
b3-03	SpdSrch Dec Time	2.0 Sec	
b3-05	Search Delay	0.2 Sec	
b3-14	Bidir Search Sel	1	
b4-01	Delay-ON Timer	0.0 Sec	
b4-02	Delay-OFF Timer	0.0 Sec	
b5-01	PI Mode	0	
b5-02	P Gain	2	
b5-03	PI I Time	5.0 Sec	
b5-04	PI I Limit	100.00%	
b5-06	PI Limit	100.00%	
b5-07	PI Offset	0.00%	
b5-08	PI Delay Time	0.0 Sec	
b5-09	Output Level Sel	0	
b5-10	Output Gain	1	
b5-11	Output Rev Sel	0	
b5-12	Fb los Det Sel	0	
b5-13	Fb los Det Lvl	0%	
b5-14	Fb los Det Time	1.0 Sec	
b5-15	Sleep Level	0.0 Hz	
b5-16	Sleep Time	0.0 Sec	
b5-17	Acc/Dec Time	0.0 Sec	
b5-18	PI Setpoint Sel	0	
b5-19	PI Setpoint	0.00%	

Table 5.1- Registers Notes

Prm	Function	Default	Notes
b5-20	Setpoint Scaling	1	
b5-21	PI Sleep Source	1	
b5-22	Snooze Level	0%	
b5-23	Snooze DelayTime	0 Sec	
b5-24	Wake-Up Level	0%	
b5-25	Setpoint Boost	0%	
b5-26	Max Boost Time	0 Sec	
b5-27	Snooze Feedback	60%	
b5-28	PI Feedback SqRt	0	
b5-29	PI Fb SqRt Gain	0	
b5-30	PI Out Moni SqRt	0	
b8-01	Energy Save Sel	0	
b8-04	Energy Save COEF	288.2	
b8-05	kW Filter Time	20 ms	
b8-06	Search V Limit	0%	
C1-01	Accel Time 1	30.0 Sec	
C1-02	Decel Time 1	30.0 Sec	
C1-03	Accel Time 2	30.0 Sec	
C1-04	Decel Time 2	30.0 Sec	
C1-09	Fast Stop Time	30.0 Sec	
C1-11	Acc/Dec SW Freq	0.0 Hz	
C2-01	SCrv Acc @ Start	0.2 Sec	
C2-02	SCrv Acc @ End	0.2 Sec	
C4-01	Torq Comp Gain	1	
C4-02	Torq Comp Time	200 ms	
C6-02	CarrierFreq Sel	6h	
C6-03	CarrierFreq Max	2.0 kHz	
C6-04	CarrierFreq Min	2.0 kHz	
C6-05	CarrierFreq Gain	0	
d1-01	Reference 1	0.0 Hz	
d1-02	Reference 2	0.0 Hz	
d1-03	Reference 3	0.0 Hz	
d1-04	Reference 4	0.0 Hz	
d1-17	Jog Reference	6.0 Hz	
d2-01	Ref Upper Limit	100.00%	
d2-02	Ref Lower Limit	0.00%	
d2-03	Ref1 Lower Limit	0.00%	
d3-01	Jump Freq 1	0.0 Hz	

Table 5.1- Registers Notes

Prm	Function	Default	Notes
d3-02	Jump Freq 2	0.0 Hz	
d3-03	Jump Freq 3	0.0 Hz	
d3-04	Jump Bandwidth	1.0 Hz	
d4-01	MOP Ref Memory	0	
d4-02	Trim Control Lvl	10%	
E1-01	Input Voltage	240 VAC	
E1-03	V/F Selection	0Fh	
E1-04	Max Frequency	60.0 Hz	
E1-05	Max Voltage	240.0 VAC	
E1-06	Base Frequency	60.0 Hz	
E1-07	Mid Frequency A	3.0 Hz	
E1-08	Mid Voltage A	13.0 VAC	
E1-09	Min Frequency	1.5 Hz	
E1-10	Min Voltage	9.0 VAC	
E1-11	Mid Frequency B	0.0 Hz	
E1-12	Mid Voltage B	0.0 VAC	
E1-13	Base Voltage	240.0 VAC	
E2-01	Motor Rated FLA	14.0 A	
E2-03	No-Load Current	4.5 A	
E2-05	Term Resistance	0.771 Ohm	
F6-01	Comm Bus Flt Sel	0	
F6-02	EF0 Detection	0	
F6-03	EF0 Fault Action	1	
F6-05		0	
H1-01	Terminal S3 Sel	24h	
H1-02	Terminal S4 Sel	14h	
H1-03	Terminal S5 Sel	03h	
H1-04	Terminal S6 Sel	04h	
H1-05	Terminal S7 Sel	06h	
H2-01	Term M1-M2 Sel	0h	
H2-02	Term M3-M4 Sel	0Ah	
H3-02	Terminal A1 Gain	100.00%	
H3-03	Terminal A1 Bias	0.00%	
H3-08	Term A2 Signal	2	
H3-09	Terminal A2 Sel	2h	
H3-10	Terminal A2 Gain	100.00%	
H3-11	Terminal A2 Bias	0.00%	
H3-12	Filter Avg Time	0.3 Sec	

Table 5.1- Registers Notes

Prm	Function	Default	Notes
H3-13	TA1/A2 Select	0	
H4-01	Terminal FM Sel	02h	
H4-02	Terminal FM Gain	100.00%	
H4-03	Terminal FM Bias	0.00%	
H4-04	Terminal AM Sel	08h	
H4-05	Terminal AM Gain	50.00%	
H4-06	Terminal AM Bias	0.00%	
H4-07	AO Level Select1	0	
H4-08	AO Level Select2	0	
H5-01	Serial Comm ADR	1fh	
H5-02	Serial Baud Rate	3	
H5-03	Serial Com Sel	0	
H5-04	Serial Fault Sel	3	
H5-05	Serial Flt Dtct	1	
H5-06	Transmit WaitTIM	5 ms	
H5-07	RTS Control Sel	1	
H5-08	Protocol Select	0	
H5-09	CE Detect Time	2.0 Sec	
L1-01	MOL Fault Select	1	
L1-02	MOL Time Const	8.0 min	
L1-03	Mtr OH Alarm Sel	3	
L1-04	Mtr OH Fault Sel	1	
L1-05	Mtr Temp Filter	0.2 Sec	
L2-01	PwrL Selection	2	
L2-02	PwrL Ridethru t	0.1 Sec	
L2-03	PwrL Baseblock t	0.5 Sec	
L2-04	PwrL V/F Ramp t	0.3 Sec	
L2-05	PUV Det Level	190 VDC	
L3-01	StallP Accel Sel	1	
L3-02	StallP Accel Lvl	120%	
L3-04	StallP Decel Sel	1	
L3-05	StallP Run Sel	1	
L3-06	StallP Run Level	120%	
L4-01	Spd Agree Level	0.0 Hz	
L4-02	Spd Agree Width	2.0 Hz	
L4-05	Ref Loss Sel	1	
L4-06	Fref at Floss	80.00%	
L5-01	Num of Restarts	0	

Table 5.1- Registers Notes

Prm	Function	Default	Notes
L5-02	Restart Sel	0	
L5-03	Max Restart Time	180.0 Sec	
L6-01	Torq Det 1 Sel	0	
L6-02	Torq Det 1 Lvl	15%	
L6-03	Torq Det 1 Time	10.0 Sec	
L8-02	OH Pre-Alarm Lvl	95 Deg	
L8-03	OH Pre-Alarm Sel	4	
L8-06	Ph Loss In Lvl	7.50%	
L8-09	Ground Fault Sel	1	
L8-10	Fan On/Off Sel	0	
L8-11	Fan Delay Time	300 Sec	
L8-12	Ambient Temp	45 Deg	
L8-15	OL2 Sel @ L-Spd	1	
L8-18	Soft CLA Sel	1	
L8-19	Fref During OH	20.00%	
n1-01	Hunt Prev Select	1	
n1-02	Hunt Prev Gain	1	
n3-01	HSB Decel Width	5%	
n3-02	HSB Current Ref	150%	
n3-03	HSB DwelTim@Stp	1.0 Sec	
n3-04	HSB OL Time	40 Sec	
o1-01	User Monitor Sel	6	
o1-02	Power-On Monitor	1	
o1-03	Display Scaling	0	
o1-05	LCD Contrast	3	
o1-06	Monitor Mode Sel	0	
o1-07	2nd Monitor Sel	2	
o1-08	3rd Monitor Sel	3	
o2-01	Local/Remote Key	1	
o2-02	Oper STOP Key	1	
o2-03	User Defaults	0	
o2-04	Inverter Model #	0h	
o2-05	Operator M.O.P.	1	
o2-06	Oper Detection	1	
o2-07	Elapsed Time Set	0 H	
o2-08	Elapsed Time Run	1	
o2-09	Init Mode Sel	1	
o2-10	Fan ON Time Set	0 H	

Table 5.1- Registers Notes

Prm	Function	Default	Notes
o2-12	FLT Trace Init	0	
o2-14	kWh MonitorClear	0	
o2-15	Oper HAND Key	1	
o3-01	Copy Funtion Sel	0	
o3-02	Read Allowable	0	
T1-01	Tuning Mode Sel	0	
T1-02	Mtr Rated Power	0.0 kW	
T1-04	Rated Current	0.0 A	

Hex/Dec Conversion Table

Table 5.2 – Hexadecimal-Decimal Conversion

Hex	Dec	Hex	Dec	Hex	Dec	Hex	Dec	Hex	Dec	Hex	Dec
0	0	34	52	68	104	9C	156	D0	208		
1	1	35	53	69	105	9D	157	D1	209		
2	2	36	54	6A	106	9E	158	D2	210		
3	3	37	55	6B	107	9F	159	D3	211		
4	4	38	56	6C	108	A0	160	D4	212		
5	5	39	57	6D	109	A1	161	D5	213		
6	6	3A	58	6E	110	A2	162	D6	214		
7	7	3B	59	6F	111	A3	163	D7	215		
8	8	3C	60	70	112	A4	164	D8	216		
9	9	3D	61	71	113	A5	165	D9	217		
A	10	3E	62	72	114	A6	166	DA	218		
B	11	3F	63	73	115	A7	167	DB	219		
C	12	40	64	74	116	A8	168	DC	220		
D	13	41	65	75	117	A9	169	DD	221		
E	14	42	66	76	118	AA	170	DE	222		
F	15	43	67	77	119	AB	171	DF	223		
10	16	44	68	78	120	AC	172	E0	224		
11	17	45	69	79	121	AD	173	E1	225		
12	18	46	70	7A	122	AE	174	E2	226		
13	19	47	71	7B	123	AF	175	E3	227		
14	20	48	72	7C	124	B0	176	E4	228		
15	21	49	73	7D	125	B1	177	E5	229		
16	22	4A	74	7E	126	B2	178	E6	230		
17	23	4B	75	7F	127	B3	179	E7	231		
18	24	4C	76	80	128	B4	180	E8	232		
19	25	4D	77	81	129	B5	181	E9	233		
1A	26	4E	78	82	130	B6	182	EA	234		
1B	27	4F	79	83	131	B7	183	EB	235		
1C	28	50	80	84	132	B8	184	EC	236		
1D	29	51	81	85	133	B9	185	ED	237		
1E	30	52	82	86	134	BA	186	EE	238		
1F	31	53	83	87	135	BB	187	EF	239		
20	32	54	84	88	136	BC	188	F0	240		
21	33	55	85	89	137	BD	189	F1	241		
22	34	56	86	8A	138	BE	190	F2	242		
23	35	57	87	8B	139	BF	191	F3	243		
24	36	58	88	8C	140	C0	192	F4	244		
25	37	59	89	8D	141	C1	193	F5	245		
26	38	5A	90	8E	142	C2	194	F6	246		
27	39	5B	91	8F	143	C3	195	F7	247		
28	40	5C	92	90	144	C4	196	F8	248		
29	41	5D	93	91	145	C5	197	F9	249		
2A	42	5E	94	92	146	C6	198	FA	250		
2B	43	5F	95	93	147	C7	199	FB	251		
2C	44	60	96	94	148	C8	200	FC	252		
2D	45	61	97	95	149	C9	201	FD	253		
2E	46	62	98	96	150	CA	202	FE	254		
2F	47	63	99	97	151	CB	203	FF	255		
30	48	64	100	98	152	CC	204	100	256		
31	49	65	101	99	153	CD	205				
32	50	66	102	9A	154	CE	206				
33	51	67	103	9B	155	CF	207				

E7 Drive Parameter Access



YASKAWA ELECTRIC AMERICA, INC.

E7 drives Division
16555 W. Ryerson Rd., New Berlin, WI 53151, U.S.A.
Phone: (800) YASKAWA (800-927-5292) Fax: (262) 782-3418
Internet: <http://www.E7.drives.com>

YASKAWA ELECTRIC AMERICA, INC.

Chicago-Corporate Headquarters
2121 Norman E7 drive South, Waukegan, IL 60085, U.S.A.
Phone: (800) YASKAWA (800-927-5292) Fax: (847) 887-7310
Internet: <http://www.yaskawa.com>

MOTOMAN INC.

805 Liberty Lane, West Carrollton, OH 45449, U.S.A.
Phone: (937) 847-6200 Fax: (937) 847-6277
Internet: <http://www.motoman.com>

YASKAWA ELECTRIC CORPORATION

New Pier Takeshiba South Tower, 1-16-1, Kaigan, Minatoku, Tokyo, 105-0022, Japan
Phone: 81-3-5402-4511 Fax: 81-3-5402-4580
Internet: <http://www.yaskawa.co.jp>

YASKAWA ELETRICO DO BRASIL COMERCIO LTDA.

Avenida Fagundes Filho, 620 Bairro Saude Sao Paulo-SP, Brasil CEP: 04304-000
Phone: 55-11-5071-2552 Fax: 55-11-5581-8795
Internet: <http://www.yaskawa.com.br>

YASKAWA ELECTRIC EUROPE GmbH

Am Kronberger Hang 2, 65824 Schwalbach, Germany
Phone: 49-6196-569-300 Fax: 49-6196-888-301

MOTOMAN ROBOTICS AB

Box 504 S38525, Torsas, Sweden
Phone: 46-486-48800 Fax: 46-486-41410

MOTOMAN ROBOTEC GmbH

Kammerfeldstrabe 1, 85391 Allershausen, Germany
Phone: 49-8166-900 Fax: 49-8166-9039

YASKAWA ELECTRIC UK LTD.

1 Hunt Hill Orchardton Woods Cumbernauld, G68 9LF, Scotland, United Kingdom
Phone: 44-12-3673-5000 Fax: 44-12-3645-8182

YASKAWA ELECTRIC KOREA CORPORATION

Paik Nam Bldg. 901 188-3, 1-Ga Euljiro, Joong-Gu, Seoul, Korea
Phone: 82-2-776-7844 Fax: 82-2-753-2639

YASKAWA ELECTRIC (SINGAPORE) PTE. LTD.

Head Office: 151 Lorong Chuan, #04-01, New Tech Park Singapore 556741, Singapore
Phone: 65-282-3003 Fax: 65-289-3003

TAIPEI OFFICE (AND YATEC ENGINEERING CORPORATION)

10F 146 Sung Chiang Road, Taipei, Taiwan
Phone: 886-2-2563-0010 Fax: 886-2-2567-4677

YASKAWA JASON (HK) COMPANY LIMITED

Rm. 2909-10, Hong Kong Plaza, 186-191 Connaught Road West, Hong Kong
Phone: 852-2803-2385 Fax: 852-2547-5773

BEIJING OFFICE

Room No. 301 Office Building of Beijing International Club,
21 Jianguomanwai Avenue, Beijing 100020, China
Phone: 86-10-6532-1850 Fax: 86-10-6532-1851

SHANGHAI OFFICE

27 Hui He Road Shanghai 200437 China
Phone: 86-21-6553-6600 Fax: 86-21-6531-4242

SHANGHAI YASKAWA-TONJI M & E CO., LTD.

27 Hui He Road Shanghai 200437 China
Phone: 86-21-6533-2828 Fax: 86-21-6553-6677

BEIJING YASKAWA BEIKE AUTOMATION ENGINEERING CO., LTD.

30 Xue Yuan Road, Haidian, Beijing 100083 China
Phone: 86-10-6232-9943 Fax: 86-10-6234-5002

SHOUGANG MOTOMAN ROBOT CO., LTD.

7, Yongchang-North Street, Beijing Economic & Technological Development Area,
Beijing 100076 China
Phone: 86-10-6788-0551 Fax: 86-10-6788-2878

YEA, TAICHUNG OFFICE IN TAIWAN

B1, 6F, No.51, Section 2, Kung-Yi Road, Taichung City, Taiwan, R.O.C.
Phone: 886-4-2320-2227 Fax: 886-4-2320-2239